

THIS DOCUMENT AND THE DATA DISCLOSED HEREIN OR HEREWITH IS NOT TO BE REPRODUCED, USED, OR DISCLOSED IN WHOLE OR IN PART TO ANYONE WITHOUT THE PERMISSION OF HARTFORD EICHENAUER, INC.

REVISIONS			
LTR/NO	DESCRIPTION	DATE	APPROVED
1	PRODUCTION RELEASE	08/07/01	SJH
2	ECN 033-01 (SHEET 2)	10/16/01	SJH
3	NOTES REVISED PER ECN 002-02	01/31/02	SJH
4	REVISED & REDRAWN PER ECN 024-02	07/30/02	SJH
5	ECN 018-03	8May03	JB

NOTES:

1. COLD RESISTANCE = 11.63Ω (11.30-12.93) FOR EACH ELEMENT  
WATTAGE TOLERANCE = +3% -10% AT RATED VOLTAGE
2. TUBES RECOMPACTED IN BEND AREA
3. SILVER BRAZE TUBES TO FLANGE.  
PRESSURE TEST AT 250 PSI FOR 1 MINUTE
4. NOT SHOWN: 52326 THREAD SEALANT
5. TUBE MATERIAL:  
1.4571, .034 WALL THICKNESS
6. IDENTIFICATION MARKING IN THIS AREA AS SPECIFIED ON SHEET 3
7. TIGHTEN TOP NUTS TO 25 IN-LBS TORQUE

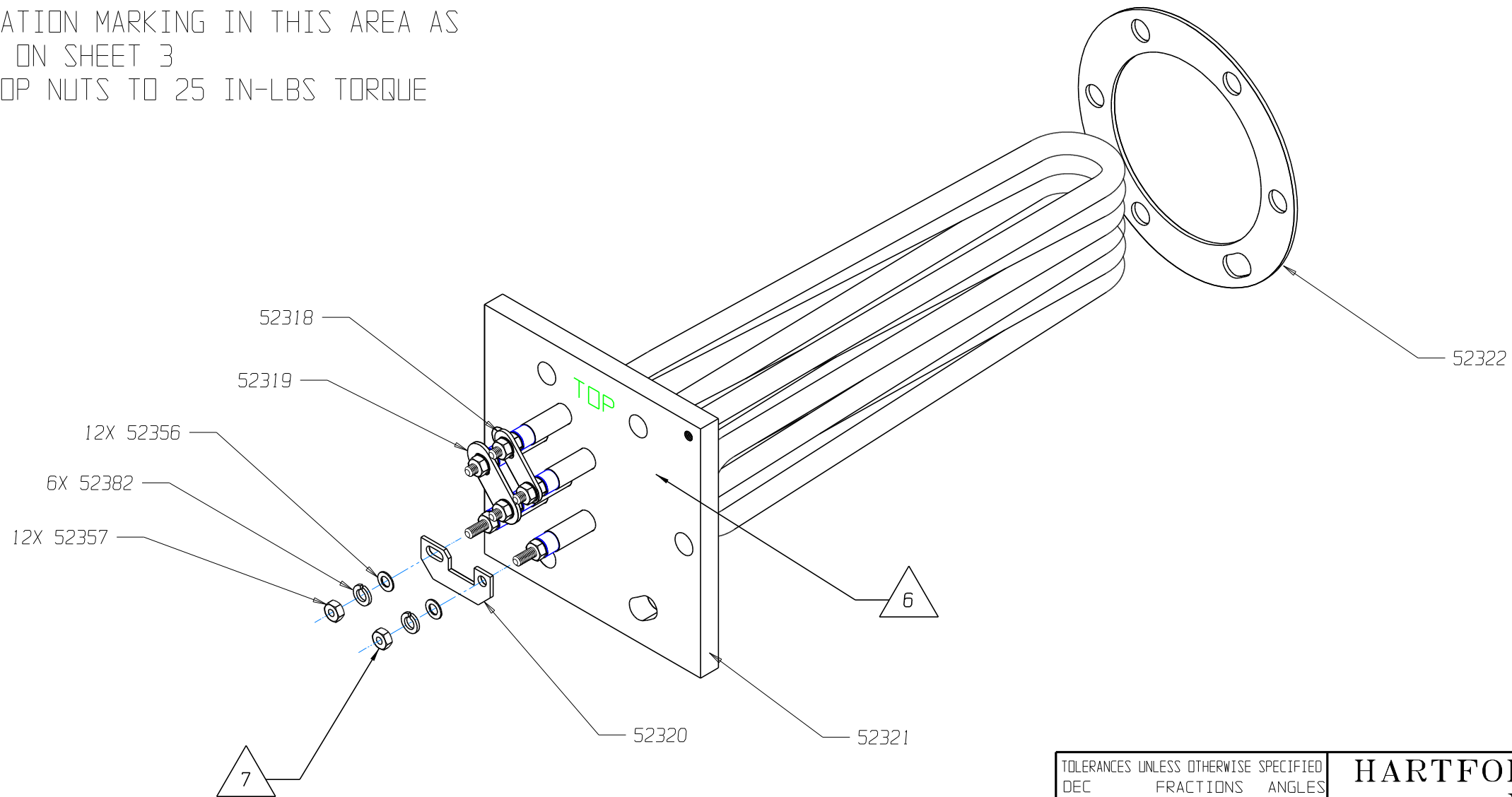

THIRD ANGLE PROJECTION

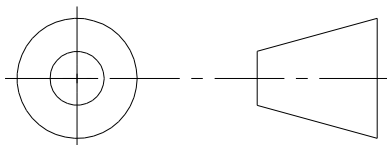

TOLERANCES UNLESS OTHERWISE SPECIFIED	
DEC	FRACTIONS ANGLES
.0 ± .06	
.00 ± .025	± 1/16 ± 1°
.000 ± .010	
APPROVALS	DATE
DRAWN S. HEBERT	08/07/01
CHECKED	

<b>HARTFORD EICHENAUER</b> <small>292 Sunapee St., Newport, NH 03773          TEL: 603-863-1454 FAX: 603-863-1248</small>			
TITLE <b>FLANGED BOILER HEATER</b> <b>220V, 12KW, 3PH</b>			
SIZE	FSCM NO.	DWG. NO.	REV.
B		<b>300407</b>	<b>5</b>
SCALE	SHEET		
1:2	1 of 3		

THIS DOCUMENT AND THE DATA DISCLOSED HEREIN OR HEREWITH IS NOT TO BE REPRODUCED, USED, OR DISCLOSED IN WHOLE OR IN PART TO ANYONE WITHOUT THE PERMISSION OF HARTFORD EICHENAUER, INC.

REVISIONS			
LTR/NO	DESCRIPTION	DATE	APPROVED
1	PRODUCTION RELEASE	08/07/01	SJH
2	B.C. DIA WAS 3 7/8 PER ECN 033-01	10/16/01	SJH
3	NOTES REVISED PER ECN 002-02	01/31/02	SJH
4	REVISED & REDRAWN PER ECN 024-02	07/30/02	SJH
5	ECN 018-03	8May03	JB

NOTES:

1. DIMENSIONS IN INCHES
2. COLD RESISTANCE =  $11.63\Omega$  (11.30-12.93) FOR EACH ELEMENT
- WATTAGE TOLERANCE = +3% -10% AT RATED VOLTAGE
3. TUBES MUST BE CONTAINED INSIDE THIS AREA (3.12 DIA CENTERED)
4. IDENTIFICATION MARKING IN THIS AREA AS SPECIFIED ON SHEET 3
5. TIGHTEN TOP NUTS TO 25 IN-LBS TORQUE

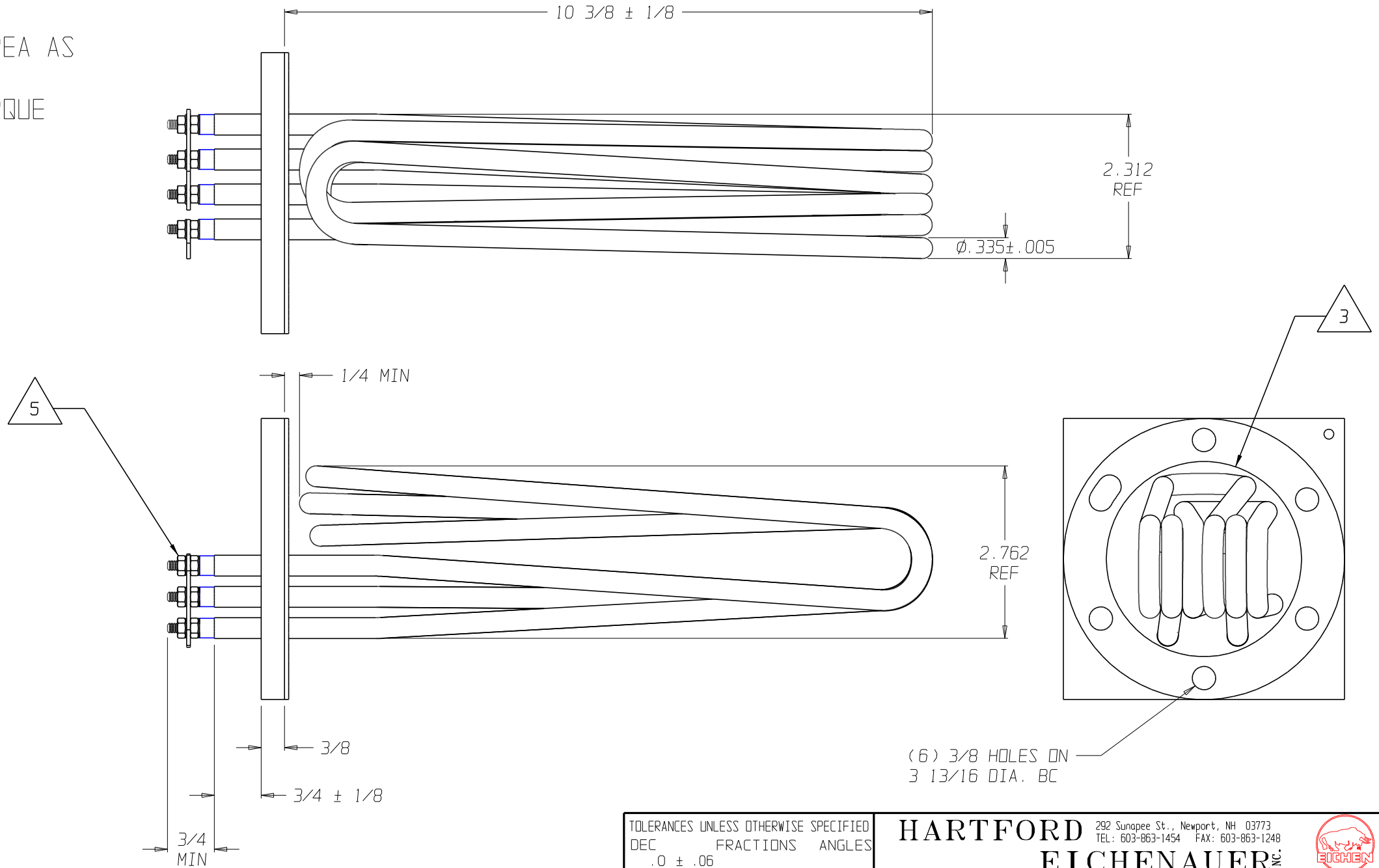
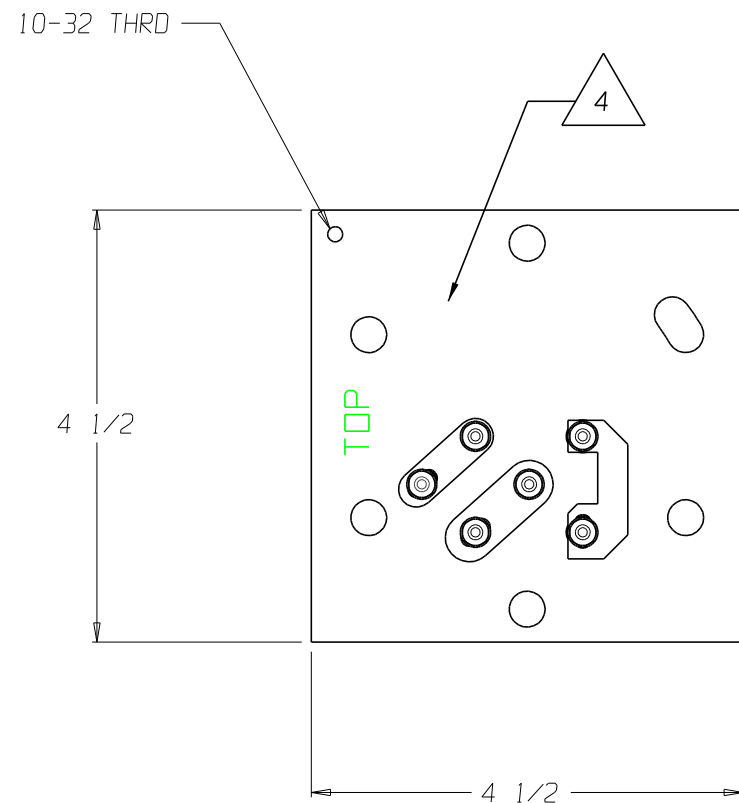

THIRD ANGLE PROJECTION

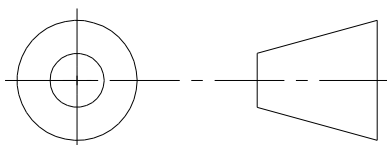

TOLERANCES UNLESS OTHERWISE SPECIFIED	
DEC	FRACTIONS ANGLES
.0 ± .06	
.00 ± .025	± 1/16 ± 1°
.000 ± .010	
APPROVALS	DATE
DRAWN S. HEBERT	08/07/01
CHECKED	

**HARTFORD EICHENAUER** 292 Sunapee St., Newport, NH 03773  
 TEL: 603-863-1454 FAX: 603-863-1248

**FLANGED BOILER HEATER**  
 220V, 12KW, 3PH

SIZE B FSCM NO. DWG. NO. 300407 REV. 5

SCALE 1:2 SHEET 2 of 3