

THIS DOCUMENT AND THE DATA DISCLOSED HEREIN OR HEREWITH IS NOT TO BE REPRODUCED, USED, OR DISCLOSED IN WHOLE OR IN PART TO ANYONE WITHOUT THE PERMISSION OF HARTFORD EICHENAUER, INC.

REVISIONS			
LTR/NO	DESCRIPTION	DATE	APPROVED
A	QUOTATION RELEASE	05/24/02	SJH
1	PRODUCTION RELEASE (WAS P1069B)	09/04/02	SJH

NOTES:

1. DIMENSIONS IN MM UDS
2. SHEATH MATERIAL: 1.4571 STAINLESS STEEL
3. ENDS OF TUBE SEALED WITH RTV SILICONE
4. FLANGE MATERIAL: NICKEL PLATED STEEL
5. SILVER BRAZE TUBES TO FLANGE - PRESSURE TEST AT 150 PSI FOR 1 MINUTE
6. TUBE DIAMETER: $10.92 \pm .13$
7. SHEATH WATT LOADING: 18.2 W/CM^2
8. NOT SHOWN: 52322 GASKET & 52326 SEALANT
9. COLD RESISTANCE = $11.3\Omega \pm 10\%/-5\%$
 $(12.4 - 10.8)$ FOR EACH ELEMENT
 COLD RESISTANCE WITH JUMPERS = $7.5\Omega \pm 10\%/-5\%$
 $(8.3 - 7.2)$

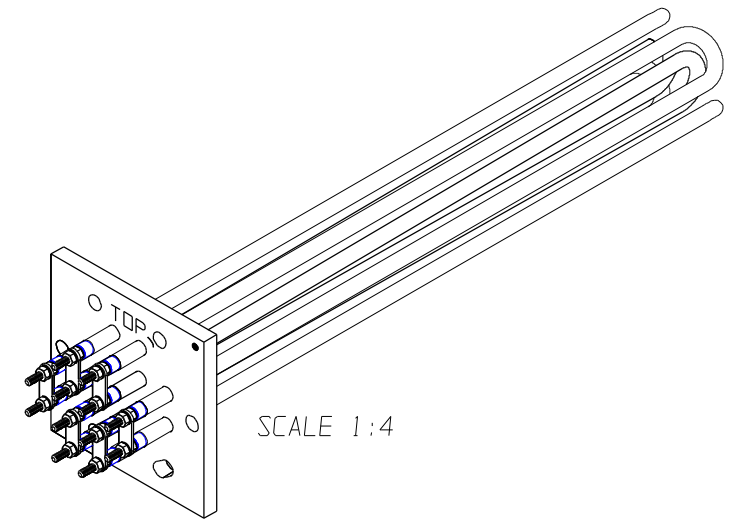
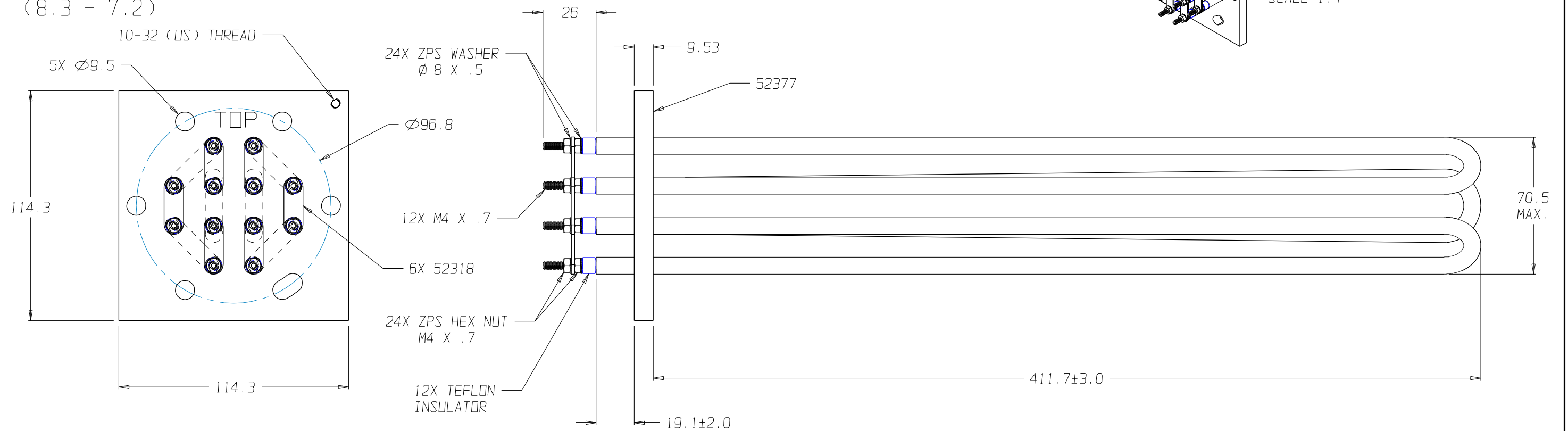

THIRD ANGLE PROJECTION

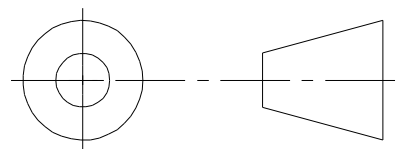

TOLERANCES UNLESS OTHERWISE SPECIFIED	
DEC	FRACTIONS ANGLES
X. ± 1.0	
X.X ± .50	± ± 1°
X.XX ± .25	
APPROVALS	DATE
DRAWN S. HEBERT	05/24/02
CHECKED -	-

HARTFORD EICHENAUER 292 Sunapee St., Newport, NH 03773
 TEL: 603-863-1454 FAX: 603-863-1248

FLANGED BOILER HEATER
 240V, 30KW, 3PH

SIZE B FSCM NO. DWG. NO. **300446** REV. **1**

SCALE 1:2 SHEET 1 of 1