

THIS DOCUMENT AND THE DATA DISCLOSED HEREIN OR HEREWITH IS NOT TO BE REPRODUCED, USED, OR DISCLOSED IN WHOLE OR IN PART TO ANYONE WITHOUT THE PERMISSION OF HARTFORD EICHENAUER, INC.

REVISIONS			
LTR/NO	DESCRIPTION	DATE	APPROVED
1	PRODUCTION RELEASE (WAS P1075)	04/09/03	SJH

NOTES:

1. DIMENSIONS IN INCHES
2. FLANGE MATERIAL: MILD STEEL
3. TUBE MATERIAL: 1.4571
4. TERMINAL PINS: M4 X .7 WITH NUTS AND WASHERS AS SHOWN
5. COLD RESISTANCE: 16.9Ω +10%/-5% (18.6 - 16.1) PER TUBE
6. BUSS TO BUSS RESISTANCE: 11.3Ω +10%/-5% (12.4 - 10.8) WHEN ASSEMBLED
7. SILVER BRAZE & TEST TO 300 PSIG
8. SHEATH WATT DENSITY: 144 W/IN²
9. COLD ZONE: 2.5" BELOW FLANGE
10. MAX TUBE BUNDLE DIA: 2-7/16

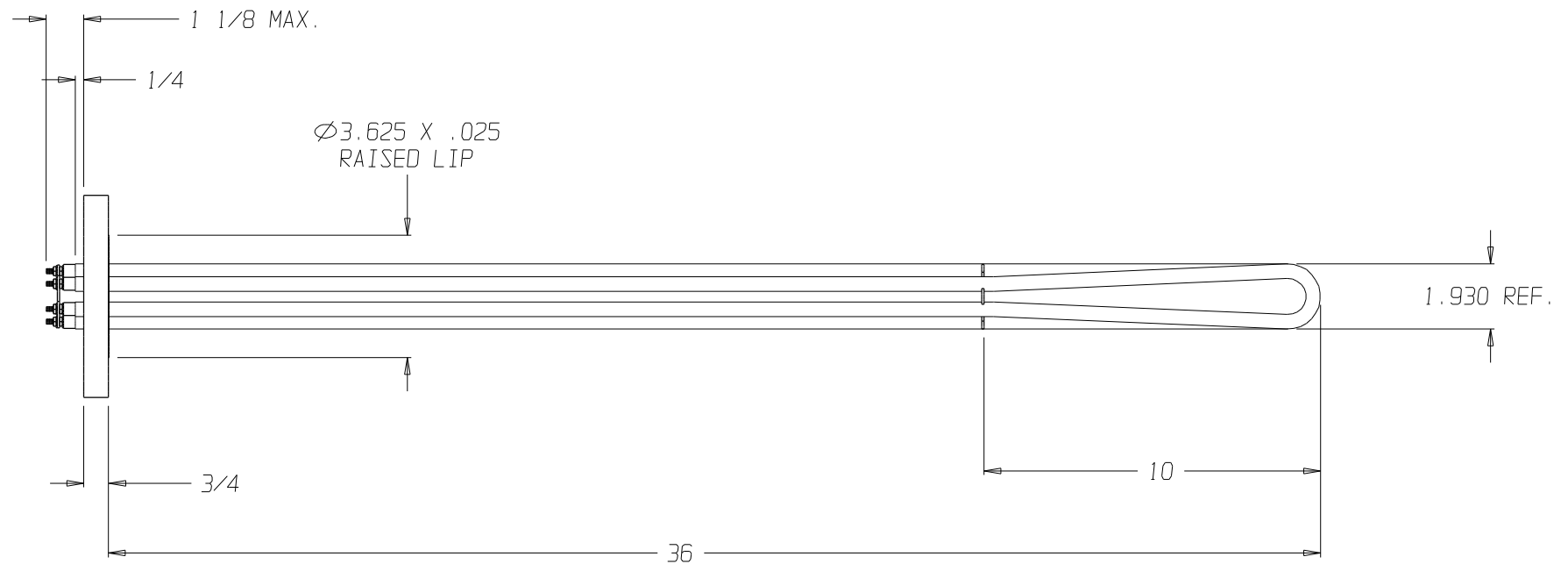
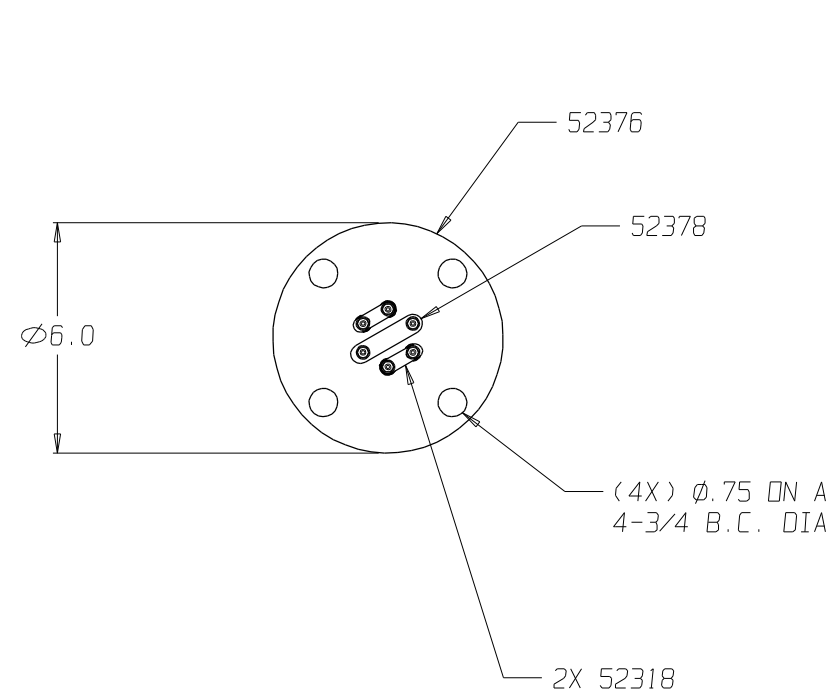
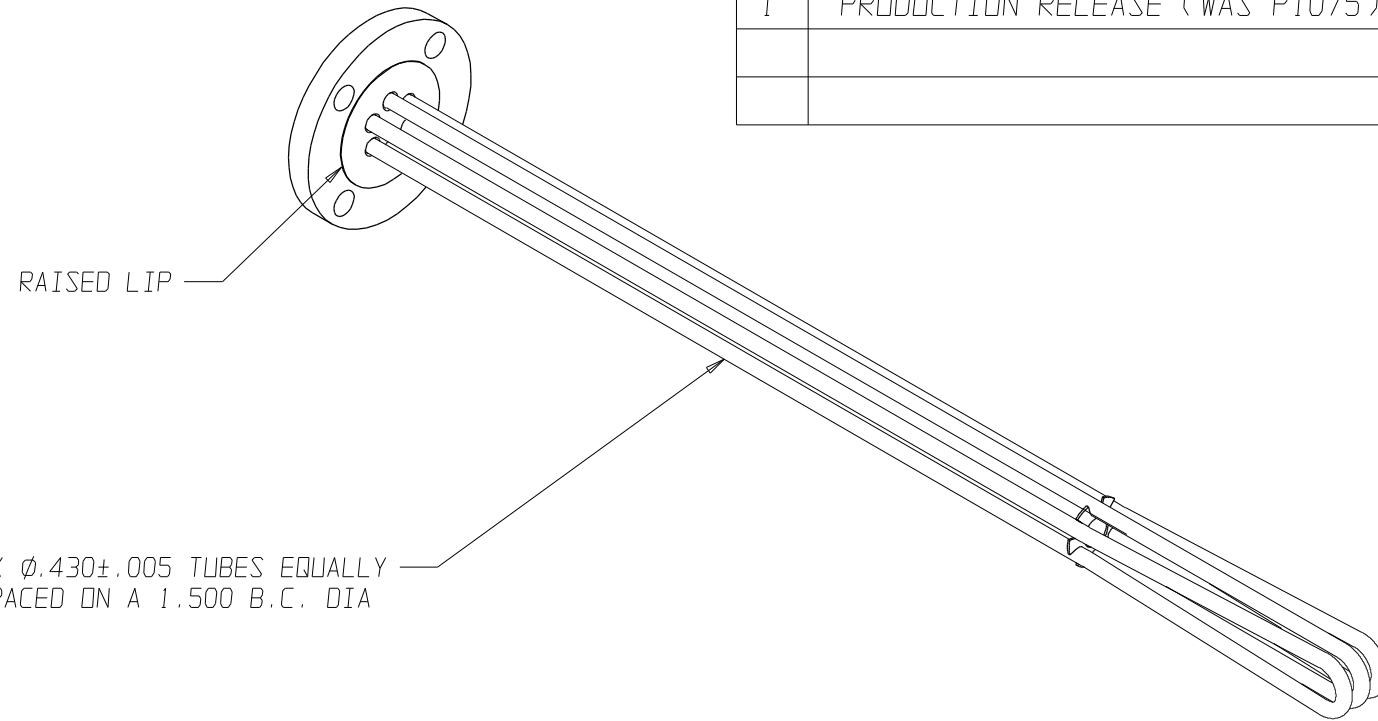

THIRD ANGLE PROJECTION

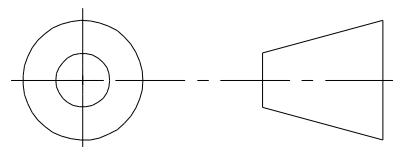

TOLERANCES UNLESS OTHERWISE SPECIFIED	
DEC	FRACTIONS ANGLES
.0 ± .06	
.00 ± .025	± 1/16 ± 1°
.000 ± .010	
APPROVALS	DATE
DRAWN S. HEBERT	04/09/03
CHECKED -	-

HARTFORD EICHENAUER 292 Sunapee St., Newport, NH 03773
 TEL: 603-863-1454 FAX: 603-863-1248

FLANGED TUBULAR HEATER
 480V 40KW 3PH

SIZE B FSCM NO. DWG. NO. **300461** REV. **1**

SCALE 1:5 SHEET 1 of 1