

THIS DOCUMENT AND THE DATA DISCLOSED HEREIN OR HEREWITH IS NOT TO BE REPRODUCED, USED, OR DISCLOSED IN WHOLE OR IN PART TO ANYONE WITHOUT THE PERMISSION OF HARTFORD EICHENAUER, INC.

REVISIONS			
LTR/NO	DESCRIPTION	DATE	APPROVED
1	PRODUCTION RELEASE (WAS P1066A)	04/10/03	SJH
2	ADDED NOTES 8 & 9 PER ECN 054-03	10/29/03	SJH

NOTES:

1. DIMENSIONS IN INCHES
2. FLANGE MATERIAL: MILD STEEL
3. TUBE MATERIAL: 1.4571
4. TERMINAL PINS: M4 X .7 WITH NUTS AND WASHERS AS SHOWN
5. COLD RESISTANCE: $6.5\Omega \pm 10\%/-5\%$ (7.2 - 6.2)
6. SILVER BRAZE TUBE TO FLANGE
7. SHEATH WATT DENSITY: 123 W/IN²
8. UL FILE E76225
MODEL 2200
9. FLANGE MARKED PER ORDER

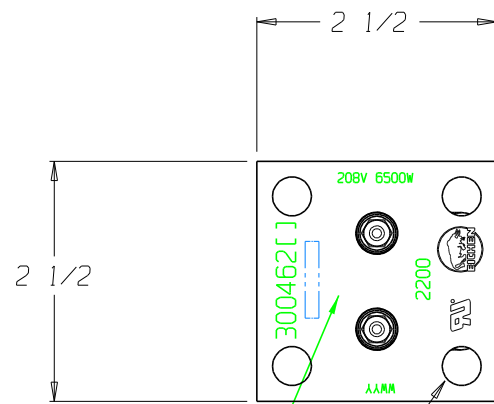
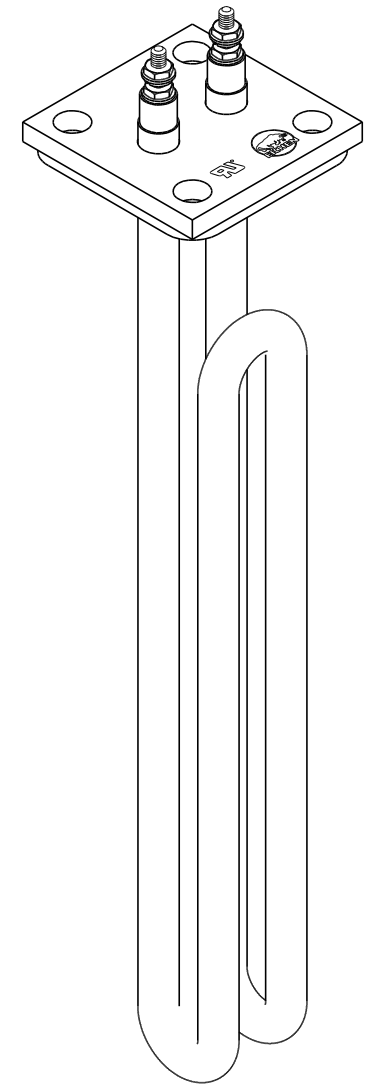
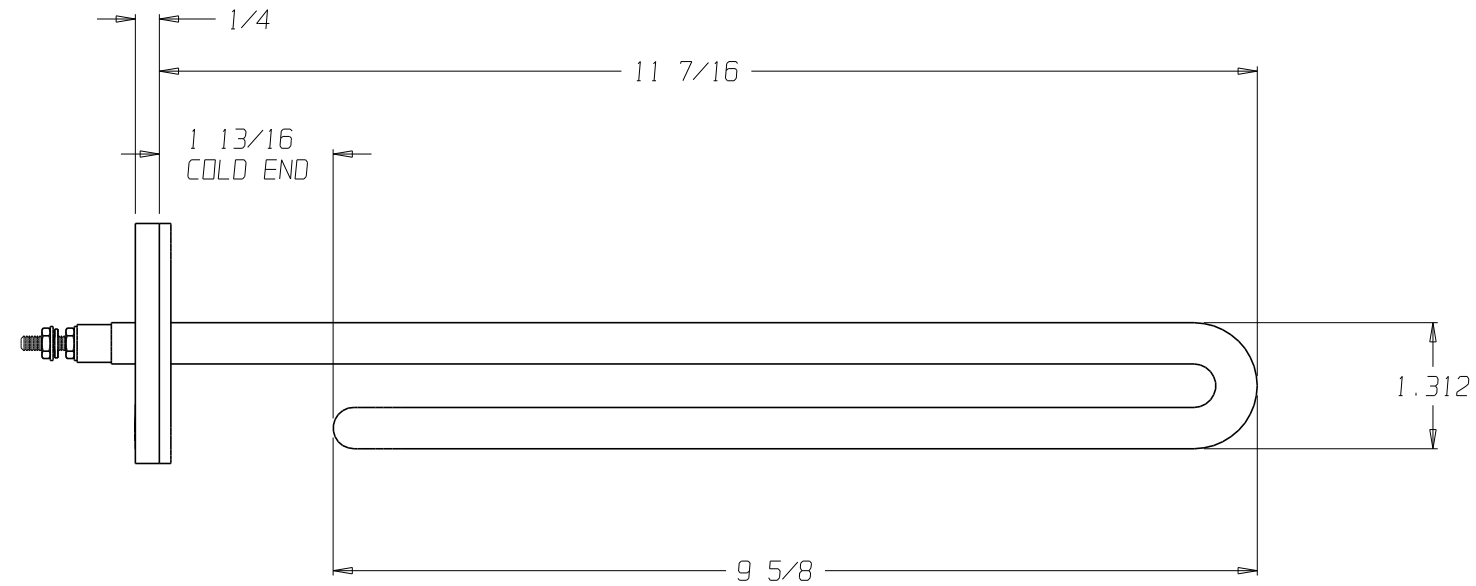

4X $\phi .406$ EQUALLY SPACED
ON 2.50 B.C. DIAMETER

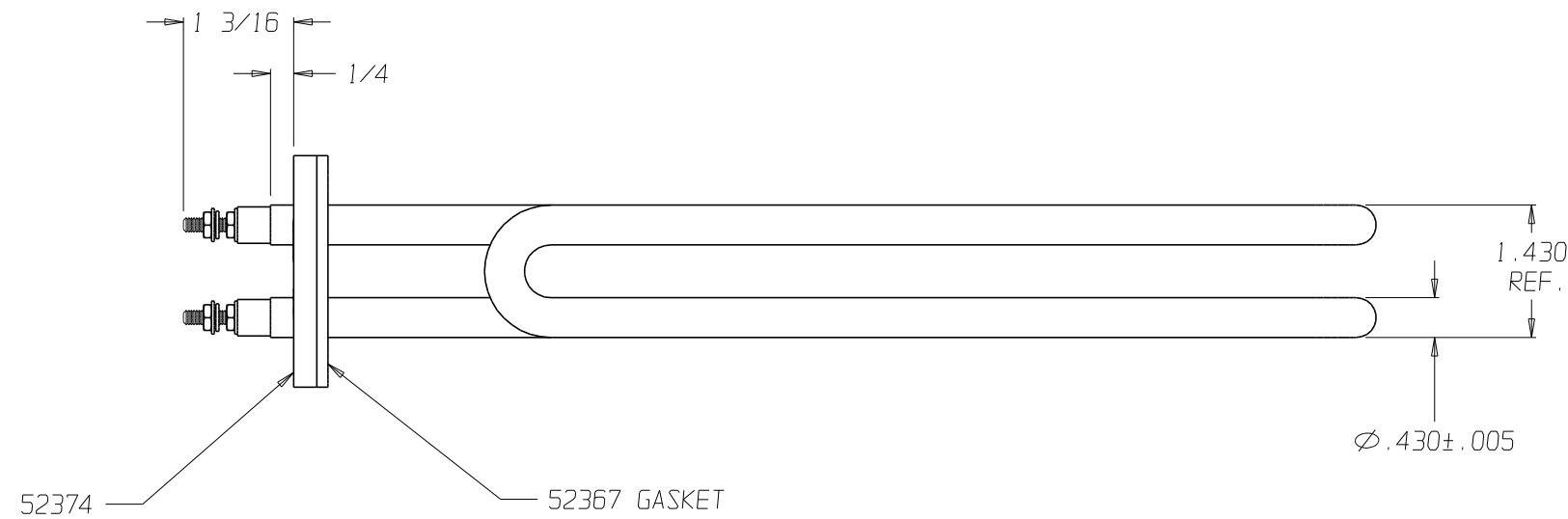

52374

52367 GASKET

THIRD ANGLE PROJECTION

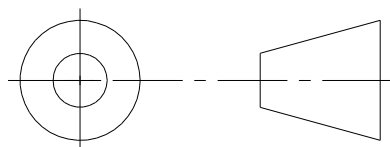

TOLERANCES UNLESS OTHERWISE SPECIFIED	
DEC	FRACTIONS ANGLES
.0 ± .06	
.00 ± .025	± 1/16 ± 1°
.000 ± .010	
APPROVALS	DATE
DRAWN S. HEBERT	04/10/03
CHECKED -	-

HARTFORD EICHENAUER 292 Sunapee St., Newport, NH 03773
TEL: 603-863-1454 FAX: 603-863-1248



TITLE **FLANGED TUBULAR HEATER**
208V, 6.5KW

SIZE B	FSCM NO.	DWG. NO. 300462	REV. 2
SCALE 1:2	SHEET 1 of 1		