

THIS DOCUMENT AND THE DATA DISCLOSED HEREIN OR HEREWITH IS NOT TO BE REPRODUCED, USED, OR DISCLOSED IN WHOLE OR IN PART TO ANYONE WITHOUT THE PERMISSION OF HARTFORD EICHENAUER, INC.

REVISIONS			
LTR/NO	DESCRIPTION	DATE	APPROVED
1	PRODUCTION RELEASE (WAS P1067C)	04/10/03	SJH
2	ECN 013-03, ADDED "TOP" TO FLANGE	15APR03	JB
3	JUMPERS REVISED PER ECN 032-04	07/30/04	SJH

NOTES:

1. DIMENSIONS IN INCHES
2. FLANGE MATERIAL: MILD STEEL
3. TUBE MATERIAL: 1.4571
4. TERMINAL PINS: M4 X .7 WITH NUTS AND WASHERS AS SHOWN
5. COLD RESISTANCE: $69.5\Omega \pm 10\%/-5\%$ (76.5 - 66.2) PER TUBE
6. BUSS TO BUSS RESISTANCE: $46.3\Omega \pm 10\%/-5\%$ (51.0 - 44.1) WHEN ASSEMBLED
7. SILVER BRAZE TUBE TO FLANGE
8. SHEATH WATT DENSITY: 100 W/IN²

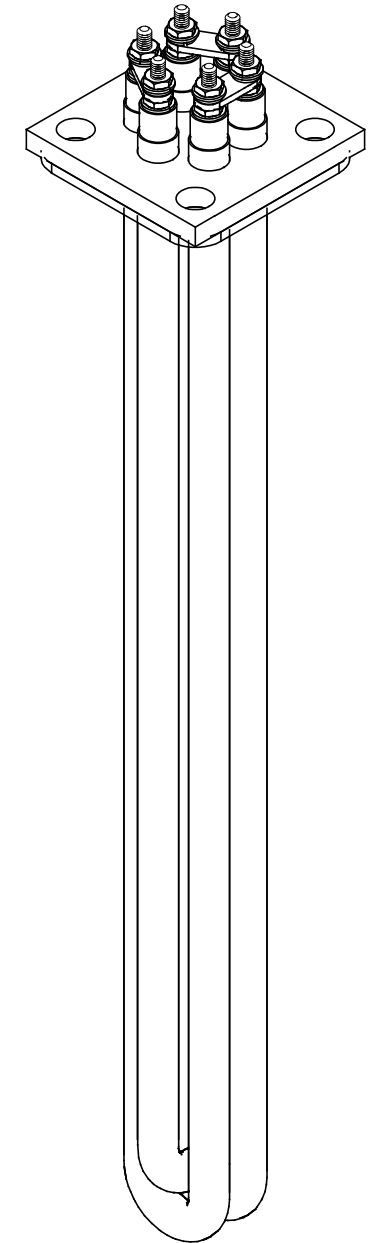
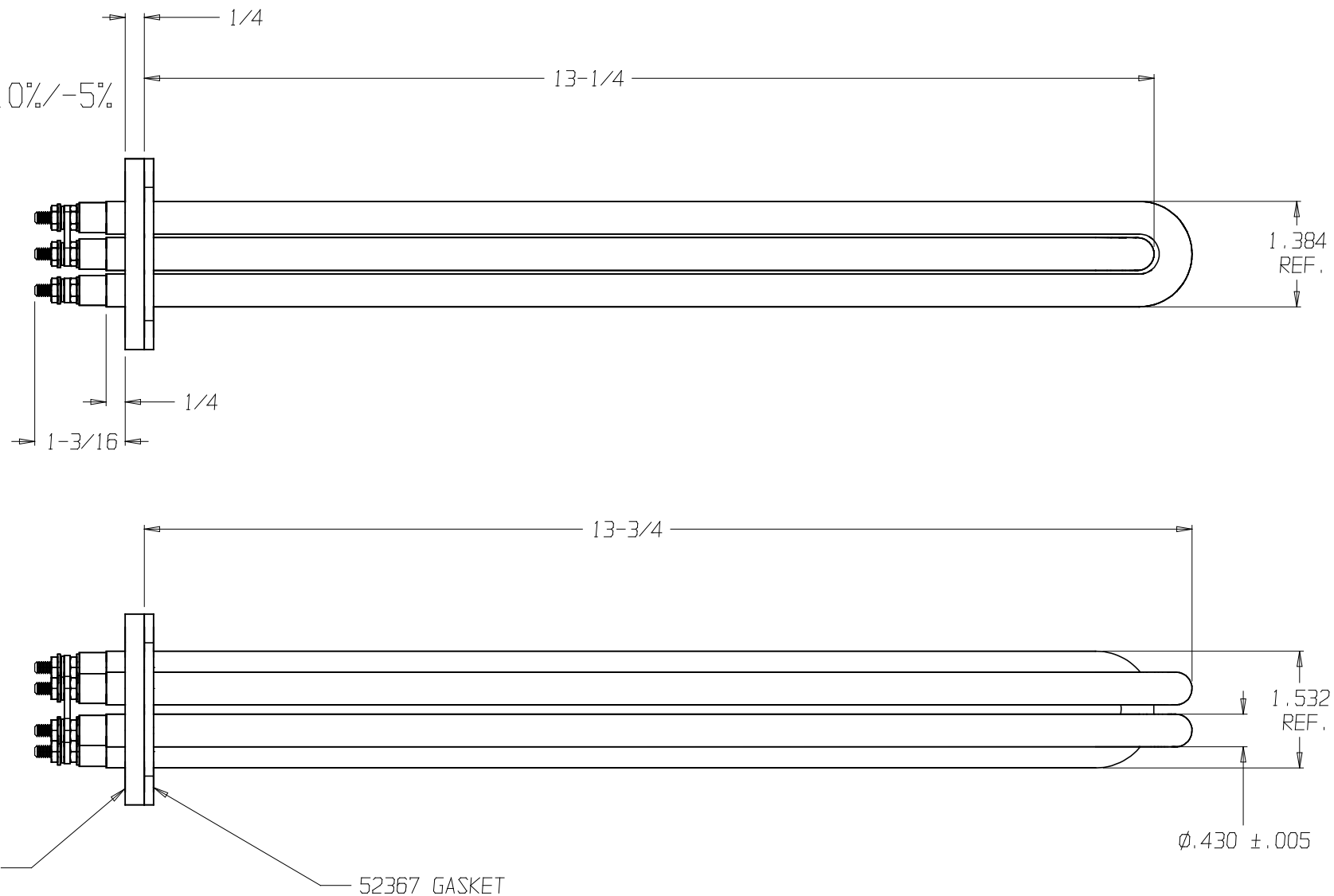
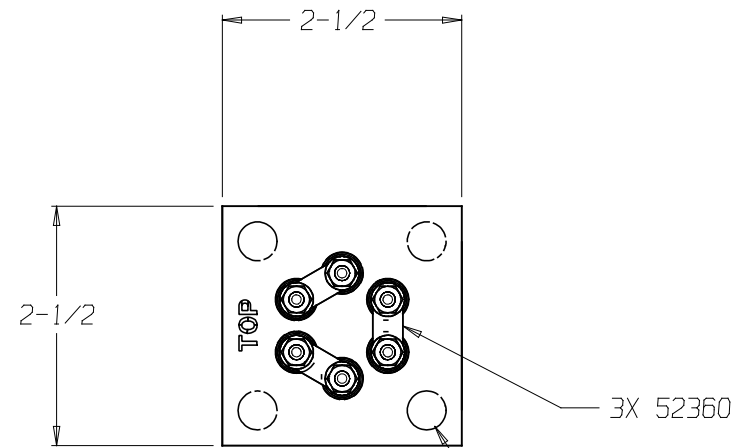

THIRD ANGLE PROJECTION

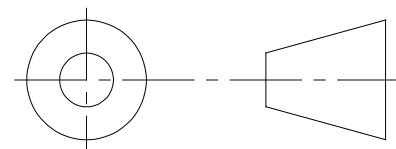

TOLERANCES UNLESS OTHERWISE SPECIFIED DEC FRACTIONS ANGLES .0 ± .06 .00 ± .025 ± 1/16 ± 1° .000 ± .010		EICHENAUER INC. 292 Sunapee St., Newport, NH 03773 TEL: 603-863-1454 FAX: 603-863-1248			
APPROVALS DRAWN S. HEBERT CHECKED -		DATE 04/10/03		TITLE FLANGED TUBULAR HEATER 480V, 9.75KW, 3PH	
SIZE B		FSCM NO.		DWG. NO. 300467	
SCALE 1:2		SHEET 1 of 1		REV. 3	