

THIS DOCUMENT AND THE DATA DISCLOSED HEREIN OR HEREWITH IS NOT TO BE REPRODUCED, USED, OR DISCLOSED IN WHOLE OR IN PART TO ANYONE WITHOUT THE PERMISSION OF HARTFORD EICHENAUER, INC.

REVISIONS			
LTR/NO	DESCRIPTION	DATE	APPROVED
A	QUOTATION RELEASE	03/23/03	SJH
1	PRODUCTION RELEASE (WAS P1101)	05/13/03	SJH

NOTES:

1. COLD RESISTANCE =  $7.1\Omega$  (7.8 - 6.7) FOR EACH ELEMENT  
WATTAGE TOLERANCE = +5% -10% AT RATED VOLTAGE
2. TUBES RECOMPACTED IN BEND AREA
3. SILVER BRAZE TUBES TO FLANGE.  
PRESSURE TEST AT 250 PSI FOR 1 MINUTE
4. NOT SHOWN: 52326 THREAD SEALANT
5. TUBE MATERIAL: 1.4571 OR EQUIVALENT
6. IDENTIFICATION MARKING IN THIS AREA AS SPECIFIED ON SHEET 3
7. TIGHTEN TOP NUTS TO 25 IN-LBS TORQUE

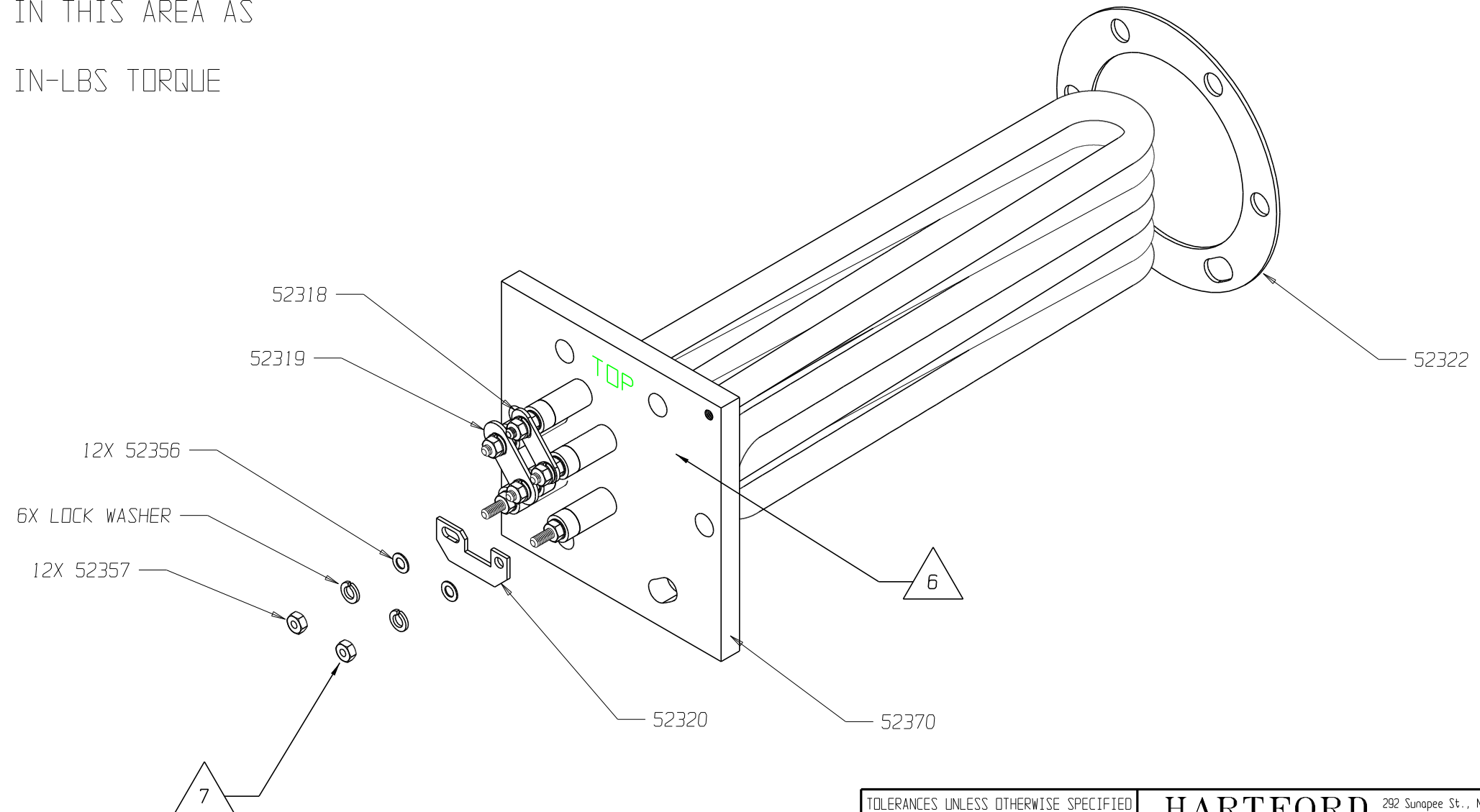

THIRD ANGLE PROJECTION

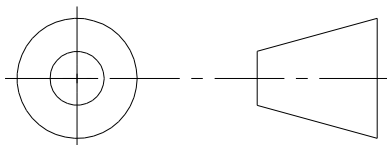

TOLERANCES UNLESS OTHERWISE SPECIFIED	
DEC	FRACTIONS ANGLES
.0 ± .06	
.00 ± .025	± 1/16 ± 1°
.000 ± .010	
APPROVALS	DATE
DRAWN S. HEBERT	05/13/03
CHECKED -	-

<b>HARTFORD EICHENAUER</b> <small>292 Sunapee St., Newport, NH 03773          TEL: 603-863-1454 FAX: 603-863-1248</small>			
TITLE <b>FLANGED BOILER HEATER</b> <b>240V, 24KW, 3PH</b>			
SIZE B	FSCM NO.	DWG. NO. <b>300475</b>	REV. <b>1</b>
SCALE 1:2	SHEET 1 of 3		

THIS DOCUMENT AND THE DATA DISCLOSED HEREIN OR HEREWITH IS NOT TO BE REPRODUCED, USED, OR DISCLOSED IN WHOLE OR IN PART TO ANYONE WITHOUT THE PERMISSION OF HARTFORD EICHENAUER, INC.

REVISIONS			
LTR/NO	DESCRIPTION	DATE	APPROVED
A	QUOTATION RELEASE	03/23/03	SJH
1	PRODUCTION RELEASE (WAS P1101)	05/13/03	SJH

NOTES:

1. DIMENSIONS IN INCHES
2. COLD RESISTANCE = 7.1  $\Omega$  (7.8 - 6.7) FOR EACH ELEMENT  
WATTAGE TOLERANCE = +5% -10% AT RATED VOLTAGE
3. TUBES MUST BE CONTAINED INSIDE THIS AREA (3.12 DIA CENTERED)
4. IDENTIFICATION MARKING IN THIS AREA AS SPECIFIED ON SHEET 3
5. TIGHTEN TOP NUTS TO 25 IN-LBS TORQUE

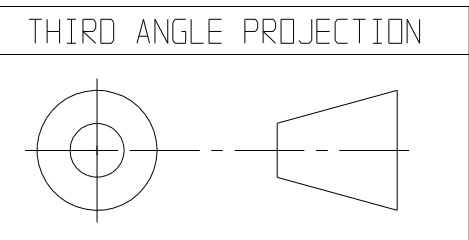
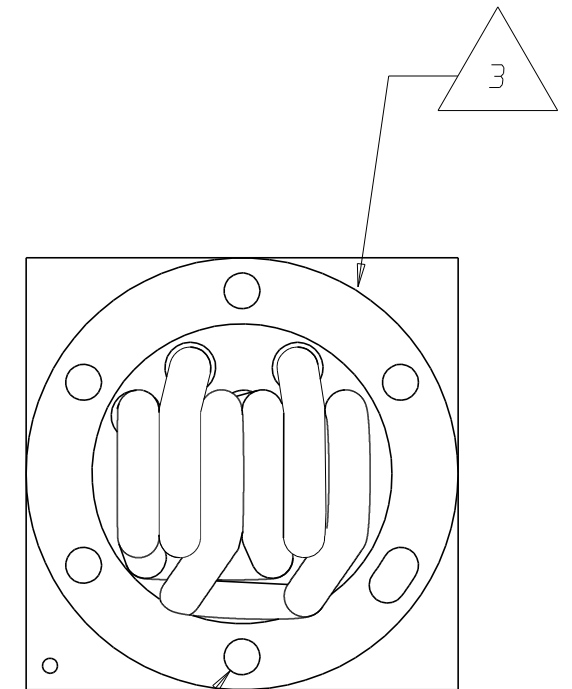
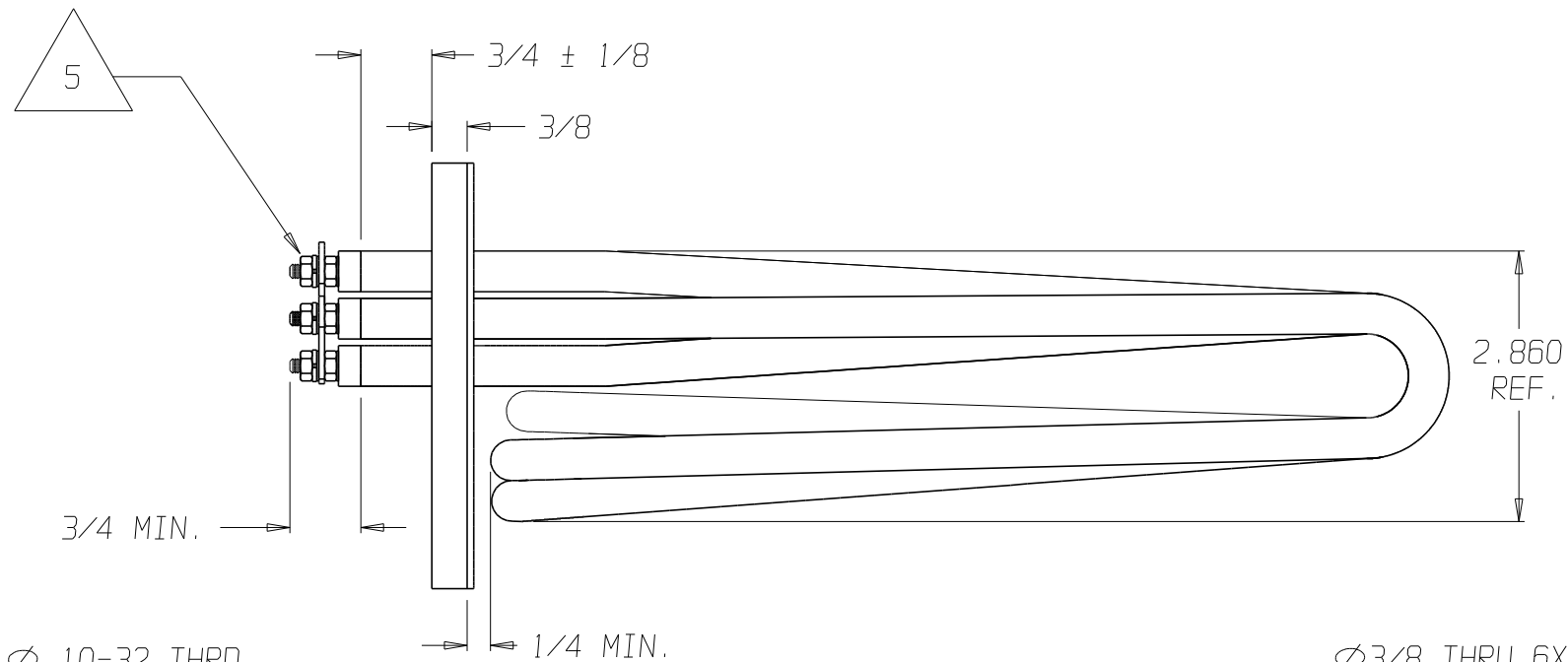
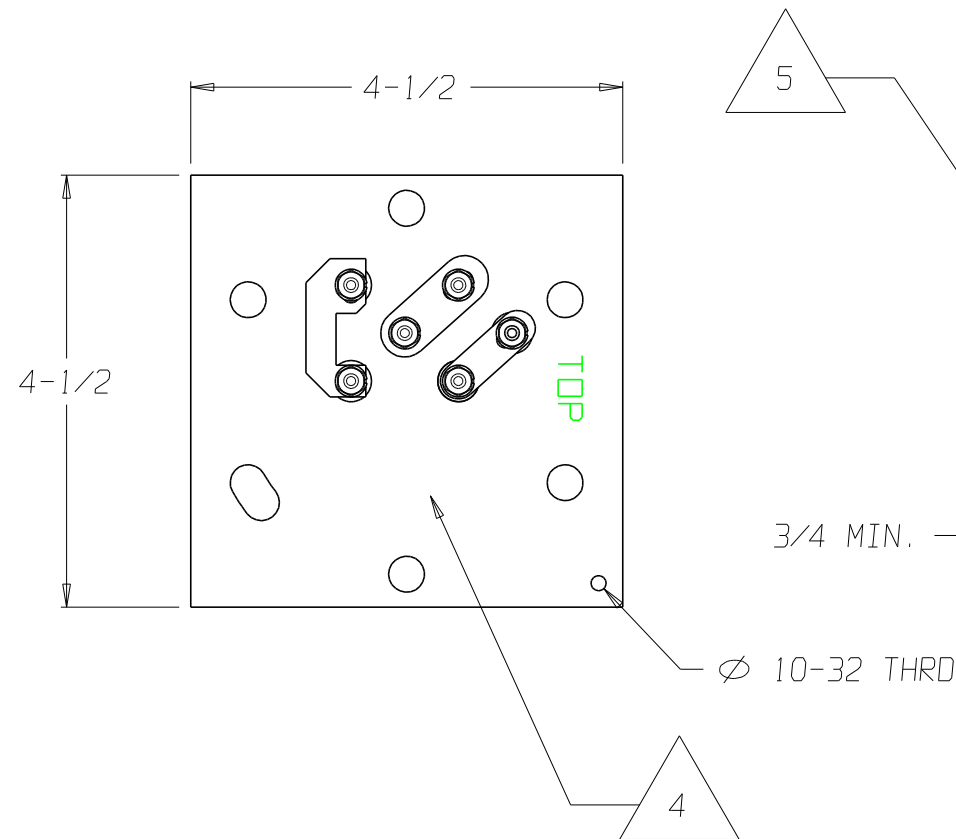
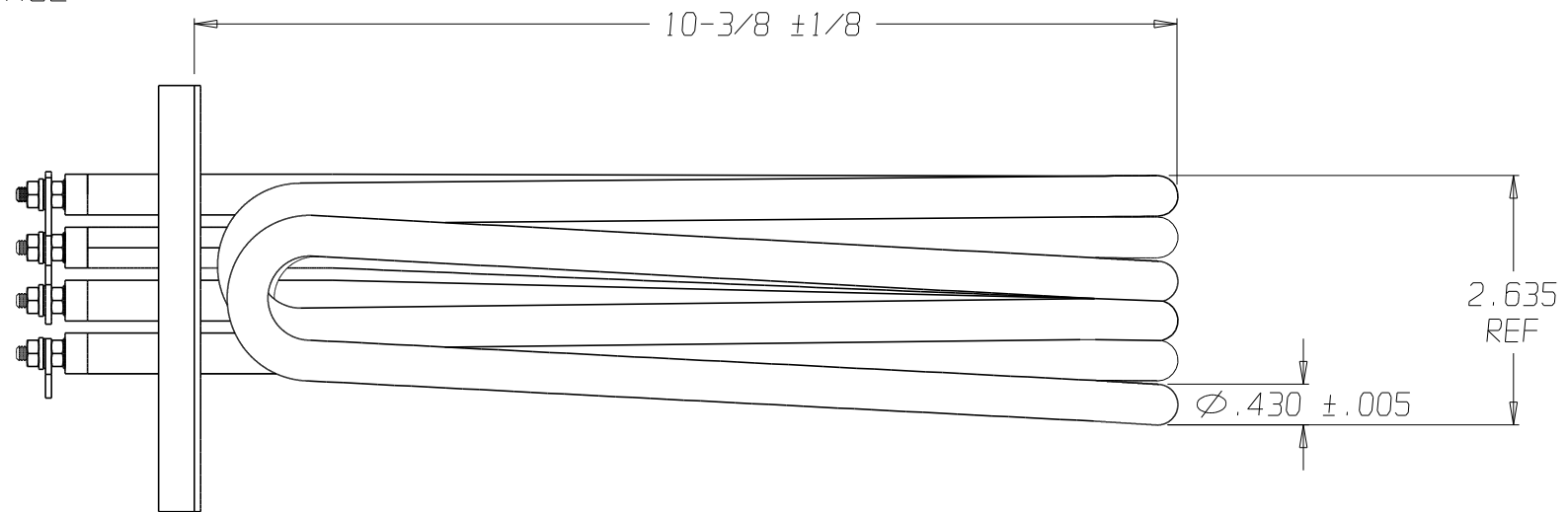

TOLERANCES UNLESS OTHERWISE SPECIFIED

DEC	FRACTIONS	ANGLES
.0 ± .06		
.00 ± .025	± 1/16	± 1°
.000 ± .010		

APPROVALS	DATE
DRAWN S. HEBERT	05/13/03
CHECKED -	-

**HARTFORD EICHENAUER** 292 Sunapee St., Newport, NH 03773  
TEL: 603-863-1454 FAX: 603-863-1248

**FLANGED BOILER ELEMENT**  
240V, 24KW, 3PH

SIZE B FSCM NO. DWG. NO. **300475** REV. **1**

SCALE 1:2 SHEET 2 of 3