

THIS DOCUMENT AND THE DATA DISCLOSED HEREIN OR HEREWITH IS NOT TO BE REPRODUCED, USED, OR DISCLOSED IN WHOLE OR IN PART TO ANYONE WITHOUT THE PERMISSION OF EICHENAUER, INC.

REVISIONS			
LTR/NO	DESCRIPTION	DATE	APPROVED
A	QUOTATION RELEASE	5/24/02	SJH
1	PRODUCTION RELEASE (WAS P1068A)	09/04/02	SJH
2	REVISED PER ECN 012-17	01/08/08	SJH

NOTES:

1. DIMENSIONS IN INCHES
2. FLANGE MATERIAL: STEEL
3. SHEATH MATERIAL: STAINLESS STEEL
4. GASKET 52322 NOT SHOWN
5. TERMINAL PINS: 10-32 WITH NUTS & WASHERS AS SHOWN. TOP NUTS TIGHTENED TO 25 IN-LBS TORQUE
6. COLD RESISTANCE: 12.7Ω +10%/-5% (12.1 - 14.0) PER TUBE
7. COLD RESISTANCE: 4.2Ω +10%/-5% (4.0 - 4.7) AS ASSEMBLED L1-L2-L3
8. SHEATH WATT DENSITY: 80 W/IN²
9. UL FILE: E76225 MODEL: 950-30-11
10. WIRING DIAGRAM: WDG-002

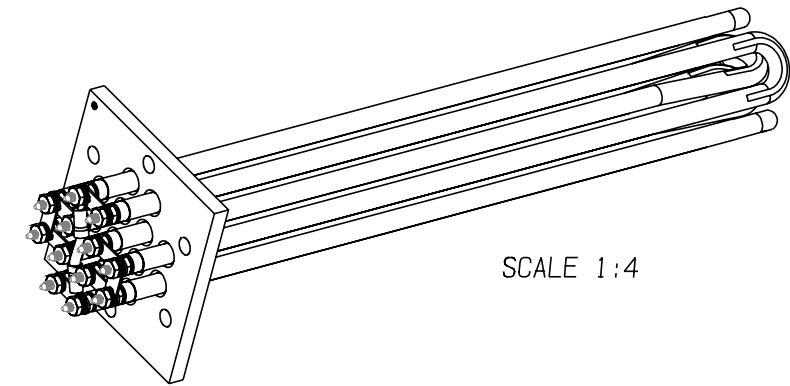

SCALE 1:4

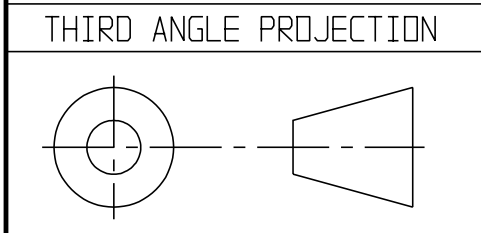
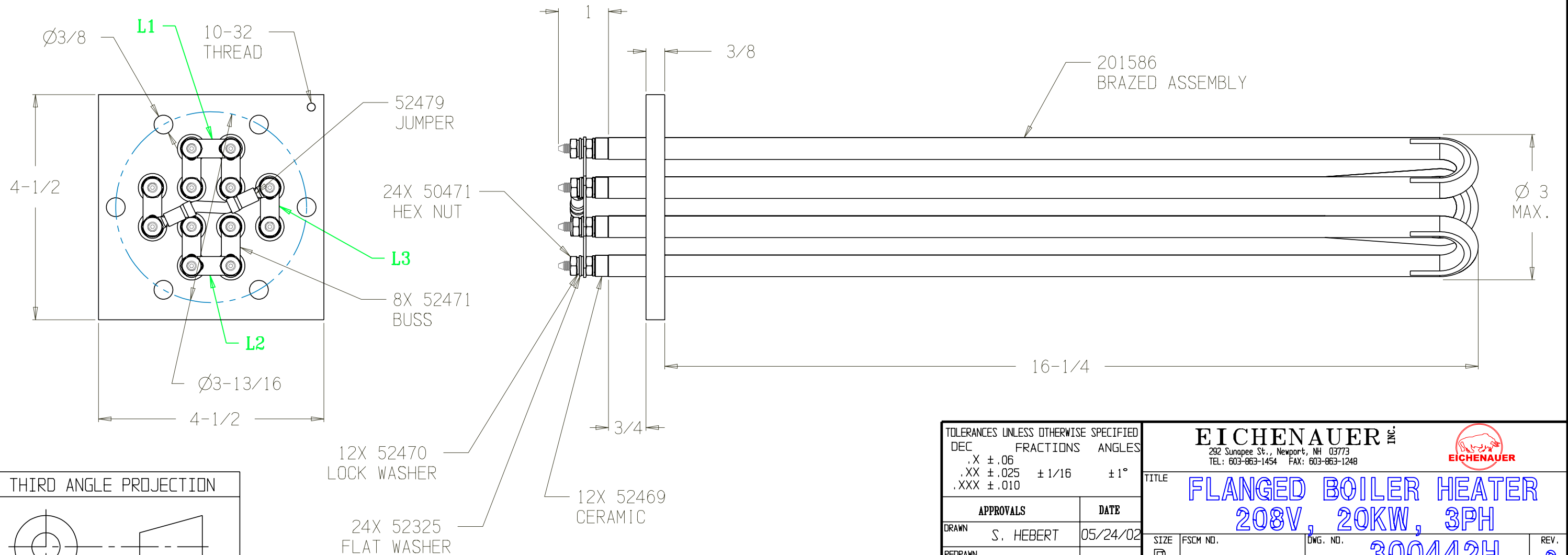

TOLERANCES UNLESS OTHERWISE SPECIFIED	
DEC	FRACTIONS ANGLES
.X ±.06	
.XX ±.025 ±1/16	±1°
.XXX ±.010	
APPROVALS	DATE
DRAWN S. HEBERT	05/24/02
REDRAWN	

EICHENAUER INC.
 292 Sunapee St., Newport, NH 03773
 TEL: 603-863-1454 FAX: 603-863-1248

TITLE **FLANGED BOILER HEATER**
208V, 20KW, 3PH

SIZE B FSCM NO. DWG. NO. **300442H** REV. **2**

SCALE 1:1 SHEET 1 of 1