

THIS DOCUMENT AND THE DATA DISCLOSED HEREIN OR HEREWITH IS NOT TO BE REPRODUCED, USED, OR DISCLOSED IN WHOLE OR IN PART TO ANYONE WITHOUT THE PERMISSION OF EICHENAUER, INC.

REVISIONS			
LTR/NO	DESCRIPTION	DATE	APPROVED
1	PRODUCTION RELEASE (WAS P1069B)	5/24/02	SJH
2	REVISED & REDRAWN PER ECN 032-10	02/08/07	SJH

NOTES:

1. DIMENSIONS IN INCHES
2. FLANGE MATERIAL: MILD STEEL
3. SHEATH MATERIAL: 1.4571
4. GASKET 52322 NOT SHOWN
5. TERMINAL PINS: 10-32 WITH NUTS & WASHERS AS SHOWN. TOP NUTS TIGHTENED TO 30 IN-LBS TORQUE
6. COLD RESISTANCE:  $11.3\Omega +10\%/-5\%$  (10.8 - 12.4) PER TUBE
7. COLD RESISTANCE:  $3.8\Omega +10\%/-5\%$  (3.6 - 4.1) AS ASSEMBLED L1-L2-L3
8. SHEATH WATT DENSITY: 121 W/IN<sup>2</sup>
9. UL FILE: E76225 MODEL: 2202
10. WIRING DIAGRAM: WDG-002

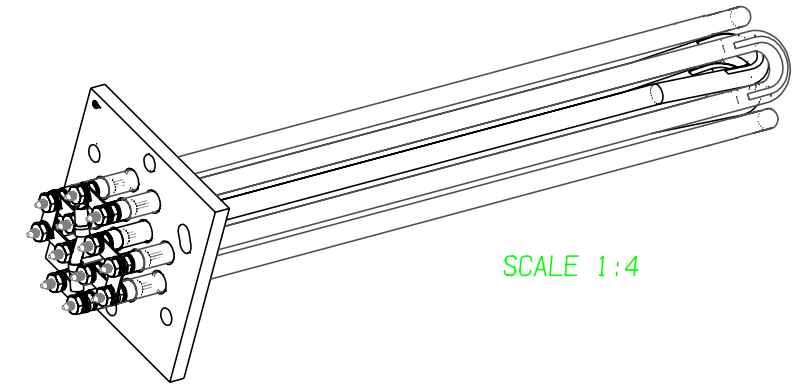

SCALE 1:4

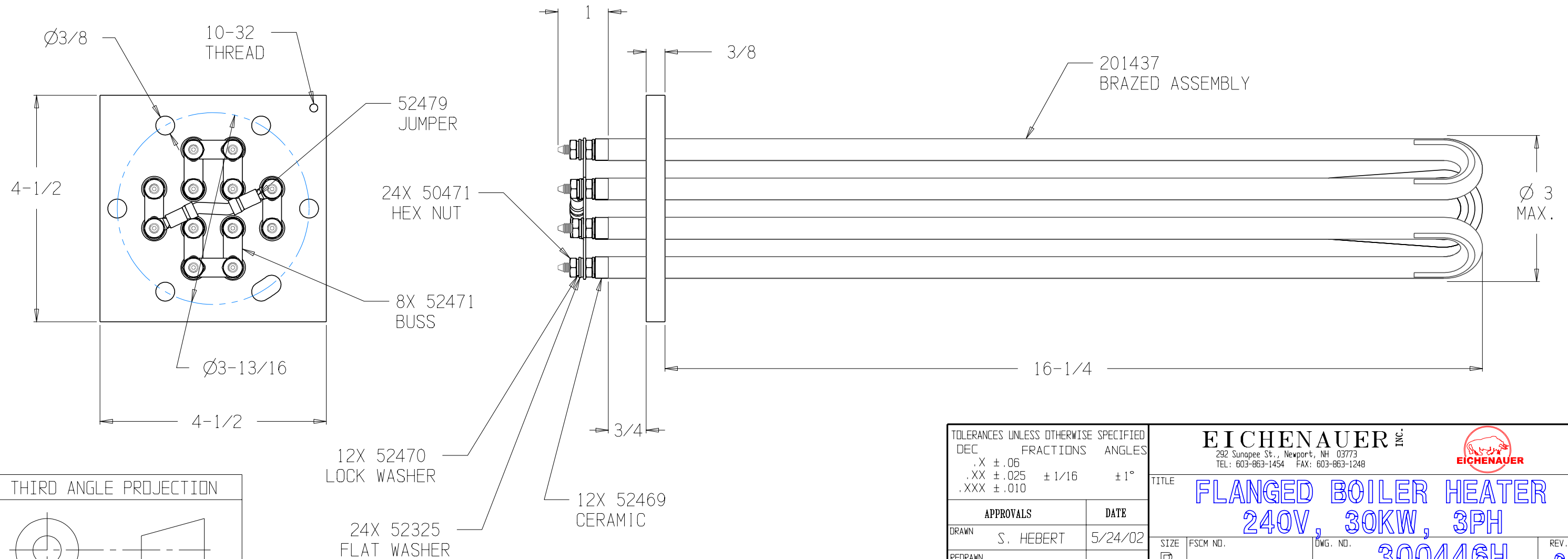

THIRD ANGLE PROJECTION

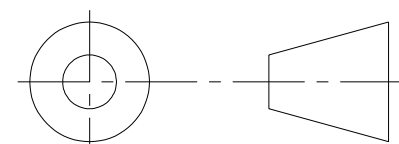

TOLERANCES UNLESS OTHERWISE SPECIFIED		
DEC	FRACTIONS	ANGLES
.X ±.06		
.XX ±.025	± 1/16	± 1°
.XXX ±.010		

**EICHENAUER INC.**  
 292 Sunapee St., Newport, NH 03773  
 TEL: 603-863-1454 FAX: 603-863-1248



TITLE		SIZE		FSCM NO.	DWG. NO.	REV.
FLANGED BOILER HEATER 240V, 30KW, 3PH		B			300446H	2
APPROVALS		DATE		SHEET		
DRAWN S. HEBERT		5/24/02		1 of 1		