

4

3

2

1

REVISIONS			
LTR/NO	DESCRIPTION	DATE	APPROVED
2	SEE ECN-003-22	20220119	MDH

NOTES:

1. REMOVED.
2. FLANGE MATERIAL: STEEL
3. SHEATH MATERIAL: 1.4571
4. GASKET 52322 NOT SHOWN
5. TERMINAL PINS: 10-32 WITH NUTS & WASHERS AS SHOWN. TOP NUTS TIGHTENED TO 25 IN-LBS TORQUE.
6. COLD RESISTANCE:  $11.3\Omega +10\%/-5\%$  (10.8 - 12.4) PER TUBE.
7. COLD RESISTANCE:  $7.5\Omega +10\%/-5\%$  (7.2 - 8.3) AS ASSEMBLED L1-L2-L3.
8. SHEATH WATT DENSITY: 121 W/IN<sup>2</sup>.
9. UL FILE: E76225 MODEL: 950-30-11
10. WIRING DIAGRAM: WDG-002.

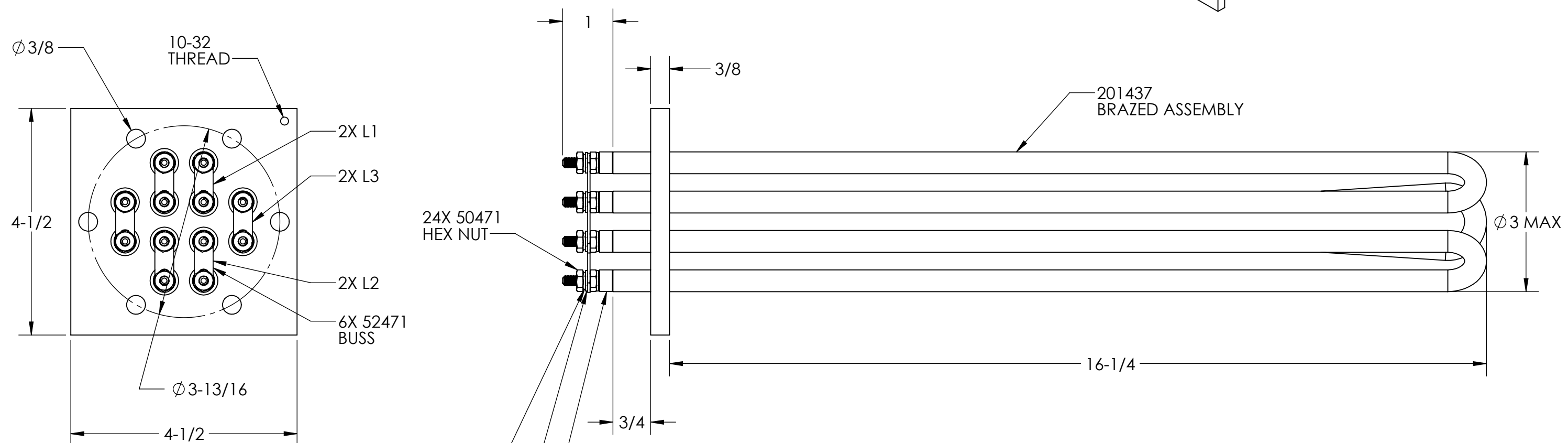
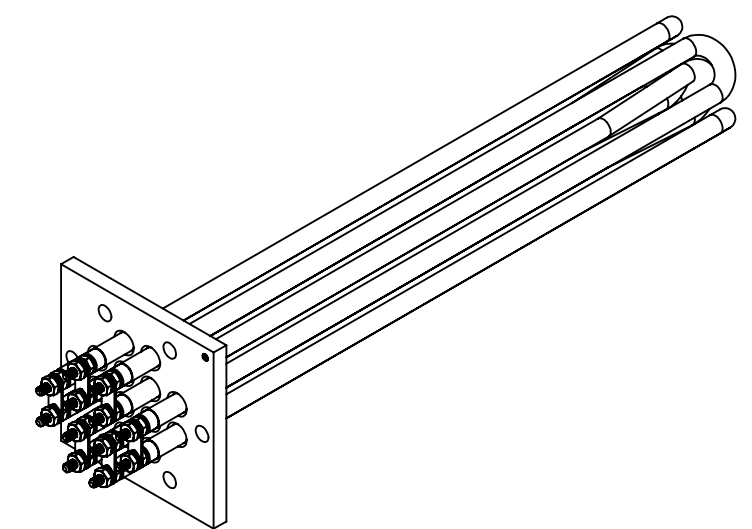

PROPRIETARY THIS DOCUMENT AND THE DATA DISCLOSED HEREIN OR HEREWITH IS NOT TO BE REPRODUCED, USED, OR DISCLOSED IN WHOLE OR IN PART TO ANYONE WITHOUT THE PERMISSION OF EICHENAUER, INC. THIRD ANGLE PROJECTION	DIMENSIONS UNLESS OTHERWISE SPECIFIED: IN/[MM]		<b>EICHENAUER INC.</b> <small>292 Sunapee St., Newport, NH 03773          TEL: 603-863-1454 FAX: 603-863-1248</small>		
	TOLERANCES UNLESS OTHERWISE SPECIFIED: DEC FRACTIONS ANGLES .X ± .1 .XX ± .03 ± 1/16 ± 1° .XXX ± .010		<b>FLANGED BOILER HEATER</b> <b>240V, 30KW, 3PH</b>		
	APPROVALS REDRAWN M. HAHN CHECKED NAME	DATE 20220119 YYYYMMDD	TITLE <b>300446K</b>	DWG. NO. <b>300446K</b>	REV. <b>2</b>
	SCALE N/A		SHEET 1 OF 1		

4

3

2

1