

4

3

2

1

REVISIONS			
LTR/NO	DESCRIPTION	DATE	APPROVED
5	SEE ECN-042-20	20201027	MDH

NOTES:

1. REMOVED.
2. FLANGE MATERIAL: STEEL
3. SHEATH MATERIAL: STAINLESS STEEL
4. TERMINAL PINS: 10-32 WITH NUTS AND WASHERS AS SHOWN. TOP NUTS TIGHTENED TO 25 IN-LBS.
5. COLD RESISTANCE  $33.9\Omega +10\%/-5\%$  (32.3 - 37.3) PER TUBE
6. COLD RESISTANCE:  $22.6\Omega +10\%/-5\%$  (21.5 - 24.8) BUSS TO BUSS
7. SHEATH WATT DENSITY: 94 W/IN<sup>2</sup>
8. UL FILE: E76225 MODEL: 965-30-11

Ø3.625 X .025  
RAISED LIP

52587  
GASKET

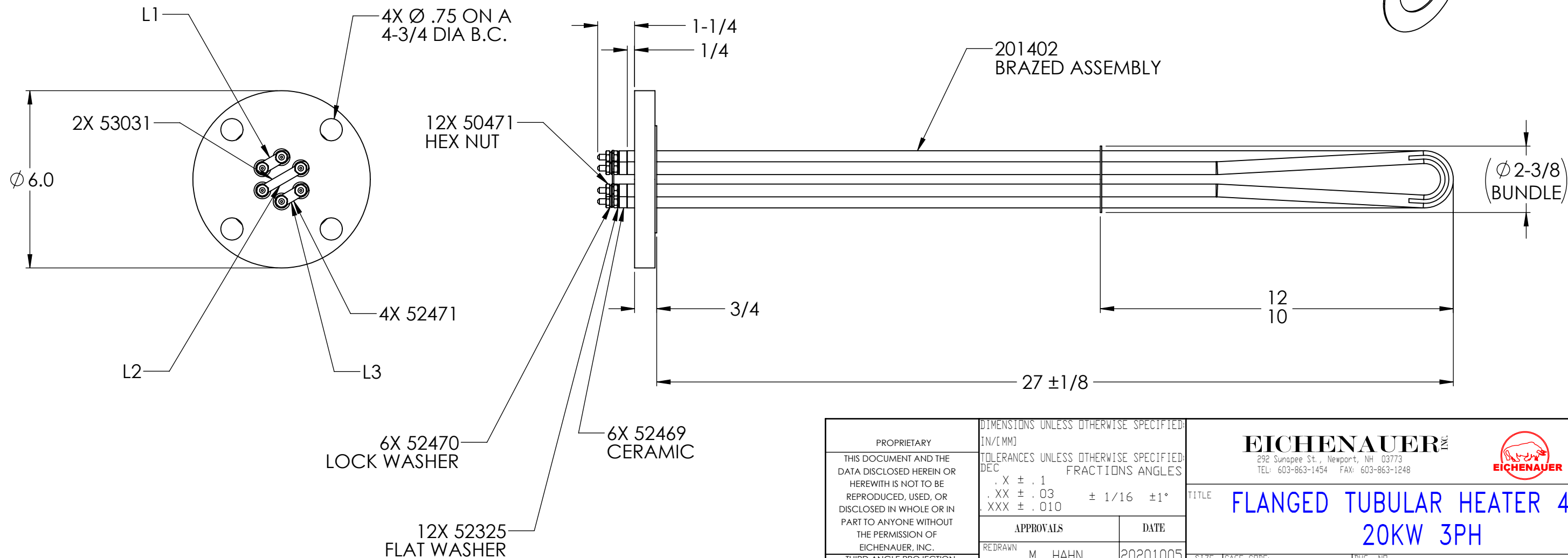

PROPRIETARY THIS DOCUMENT AND THE DATA DISCLOSED HEREIN OR HERewith IS NOT TO BE REPRODUCED, USED, OR DISCLOSED IN WHOLE OR IN PART TO ANYONE WITHOUT THE PERMISSION OF EICHENAUER, INC. THIRD ANGLE PROJECTION	DIMENSIONS UNLESS OTHERWISE SPECIFIED: IN/[MM]		<b>EICHENAUER INC.</b> 292 Sunapee St., Newport, NH 03773 TEL: 603-863-1454 FAX: 603-863-1248	
	TOLERANCES UNLESS OTHERWISE SPECIFIED: DEC FRACTIONS ANGLES .X ± .1 .XX ± .03 ± 1/16 ± 1° .XXX ± .010			
	APPROVALS REDRAWN M. HAHN CHECKED NAME		DATE 20201005 YYYYMMDD	
TITLE <b>FLANGED TUBULAR HEATER 480V 20KW 3PH</b>		SIZE <b>B</b>	CAGE CODE:	DWG. NO. <b>300460H</b>
SCALE N/A		SHEET <b>1 OF 1</b>		REV. <b>5</b>

4

3

2

1