

THIS DOCUMENT AND THE DATA DISCLOSED HEREIN OR HEREWITH IS NOT TO BE REPRODUCED, USED, OR DISCLOSED IN WHOLE OR IN PART TO ANYONE WITHOUT THE PERMISSION OF EICHENAUER, INC.

REVISIONS			
LTR/NO	DESCRIPTION	DATE	APPROVED
1	PRODUCTION RELEASE (WAS P1066A)	04/10/03	SJH
2	ADDED NOTES 8 & 9 PER ECN 054-03	10/29/03	SJH
3	REVISED PER ECN 019-13	12/12/13	SJH
4	UL # REMOVED PER ECN 011-18	3/02/18	SJH

NOTES:

1. DIMENSIONS IN INCHES
2. FLANGE MATERIAL: STEEL
3. TUBE MATERIAL: STAINLESS STEEL
4. TERMINAL PINS: #10-32 WITH NUTS & WASHERS AS SHOWN.
5. COLD RESISTANCE:  $6.5 \Omega \pm 10\% / -5\%$  (6.2 - 7.2)
6. SHEATH WATT DENSITY: 123 W/IN<sup>2</sup>

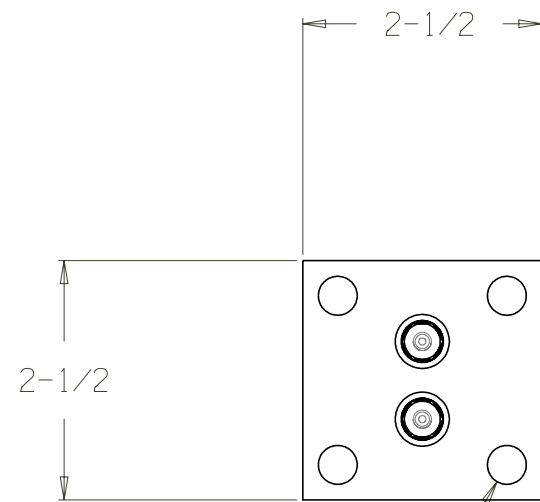

4X Ø.406 EQUALLY SPACED ON 2.50 B.C. DIAMETER

THIRD ANGLE PROJECTION

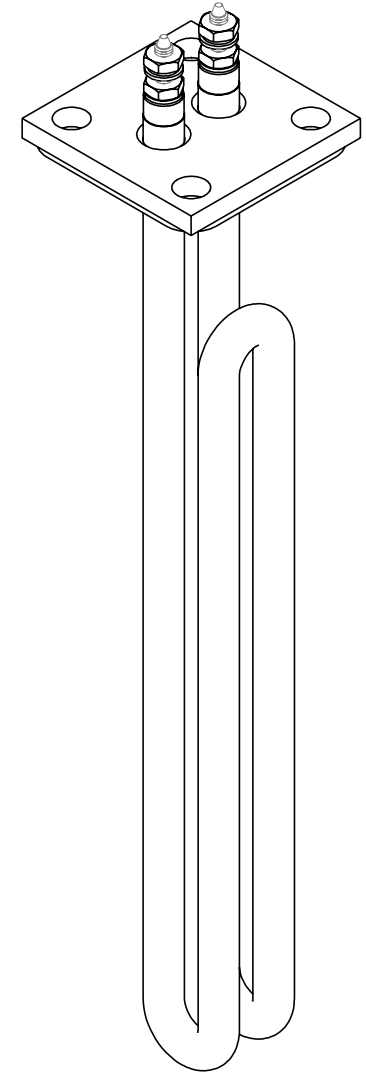
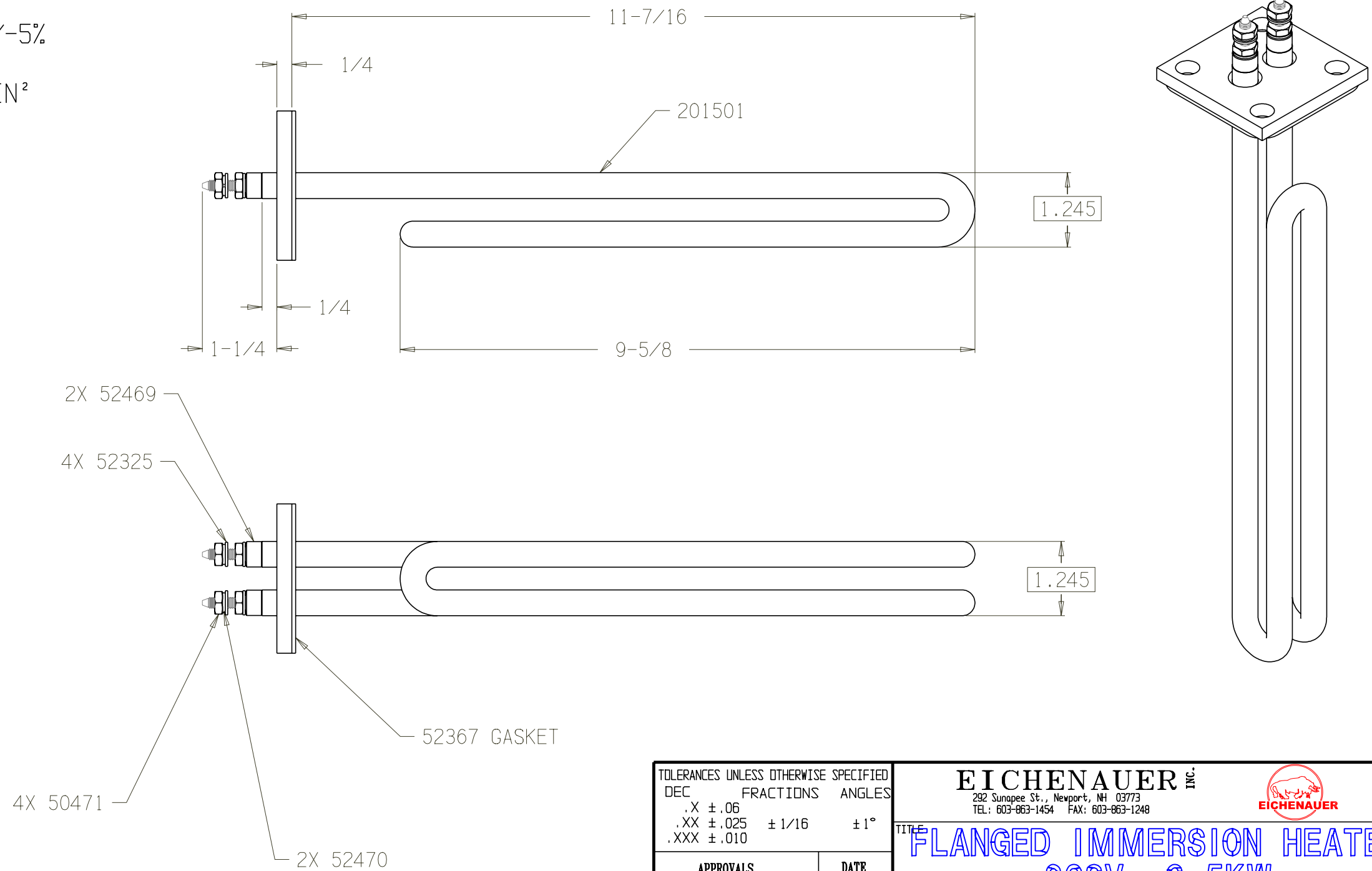
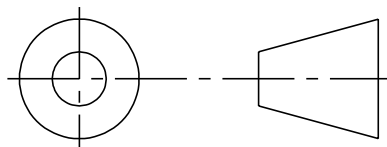

TOLERANCES UNLESS OTHERWISE SPECIFIED		<b>EICHENAUER INC.</b> 292 Sunapee St., Newport, NH 03773 TEL: 603-863-1454 FAX: 603-863-1248		
DEC	FRACTIONS	ANGLES	<b>FLANGED IMMERSION HEATER</b> <b>208V, 6.5KW</b>	
.X ± .06		± 1°	TITLE <b>300462H</b>	REV. <b>4</b>
.XX ± .025	± 1/16		APPROVALS DRAWN S. HEBERT 04/10/03	SIZE FSCM NO. <b>B</b>
.XXX ± .010			CHECKED SCALE 1:2	DWG. NO. <b>300462H</b>
			SHEET <b>1 of 1</b>	