

4

3

2

1

REVISIONS			
LTR/NO	DESCRIPTION	DATE	APPROVED
4	SEE ECN-032-20	20201023	MDH

NOTES:

1. REMOVED.
2. FLANGE MATERIAL: STEEL
3. SHEATH MATERIAL: STAINLESS STEEL
4. TERMINAL PINS: 10-32 WITH NUTS AND WASHERS AS SHOWN. TOP NUTS TIGHTENED TO 25 IN-LBS TORQUE.
5. COLD RESISTANCE: $28.2\Omega +10\%/-5\%$ (26.9 - 31.1) PER TUBE
6. BUSS TO BUSS RESISTANCE: $18.8\Omega +10\%/-5\%$ (17.9 - 20.7) WHEN ASSEMBLED L1-L2-L3
7. SHEATH WATT DENSITY: 151 W/IN^2
8. UL FILE: E76225 MODEL : 950-30-11
9. WIRING DIAGRAM: WDG-001

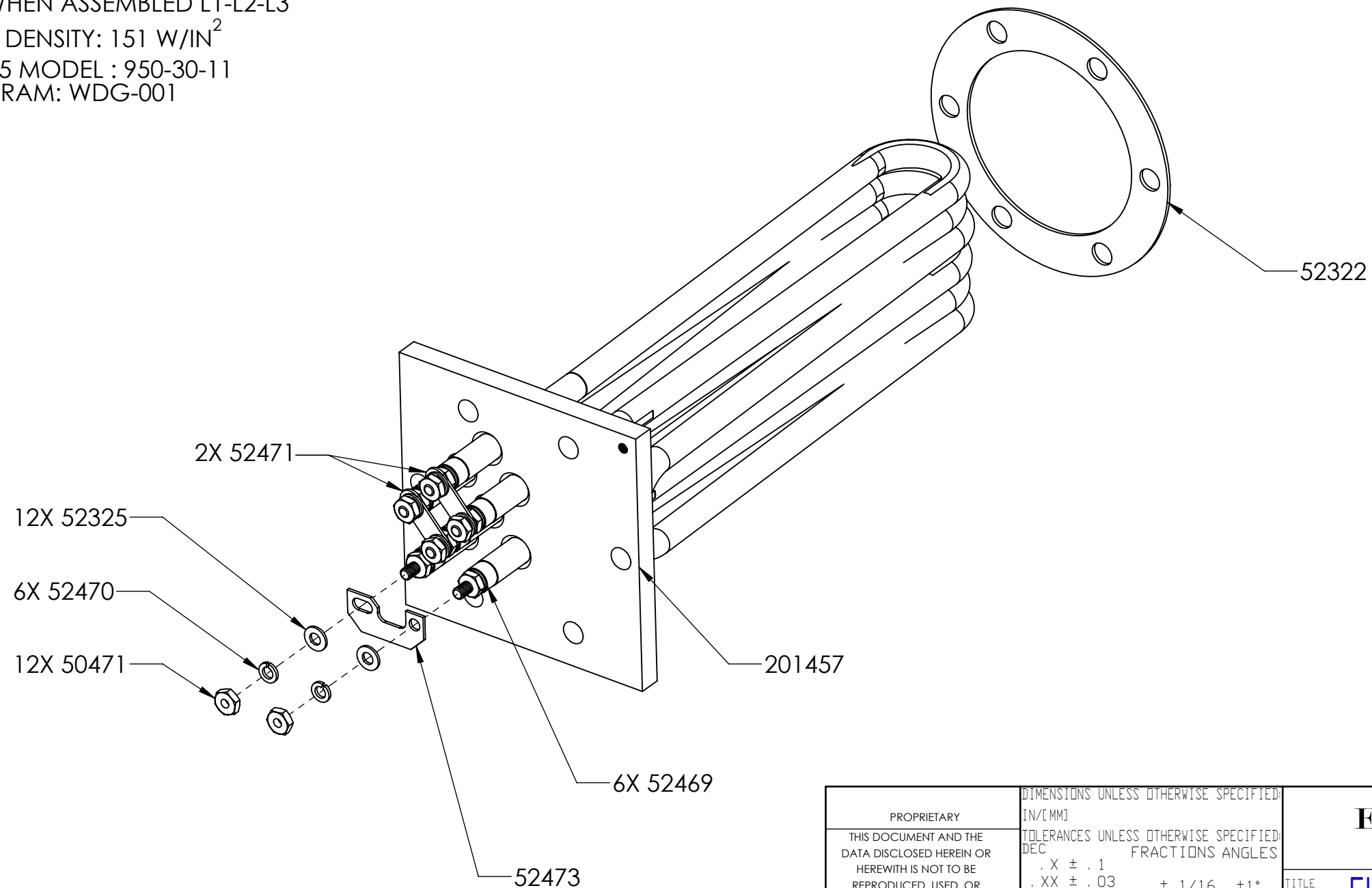

PROPRIETARY THIS DOCUMENT AND THE DATA DISCLOSED HEREIN OR HERewith IS NOT TO BE REPRODUCED, USED, OR DISCLOSED IN WHOLE OR IN PART TO ANYONE WITHOUT THE PERMISSION OF EICHENAUER, INC. THIRD ANGLE PROJECTION	DIMENSIONS UNLESS OTHERWISE SPECIFIED: IN/[MM]	EICHENAUER INC. <small>292 Sunapee St., Newport, NH 03773 TEL: 603-863-1454 FAX: 603-863-1248</small>	
	TOLERANCES UNLESS OTHERWISE SPECIFIED: DEC FRACTIONS ANGLES .X ± .1 .XX ± .03 ± 1/16 ± 1° .XXX ± .010	FLANGED BOILER HEATER 480V 24KW 3PH	
	APPROVALS REDRAWN M. HAHN CHECKED	DATE 20200928	TITLE 300476H
	SCALE N/A	DWG. NO. 300476H	SHEET 1 OF 2

4

3

2

1

4

3

2

1

REVISIONS			
LTR/NO	DESCRIPTION	DATE	APPROVED
	SEE SHEET 1		

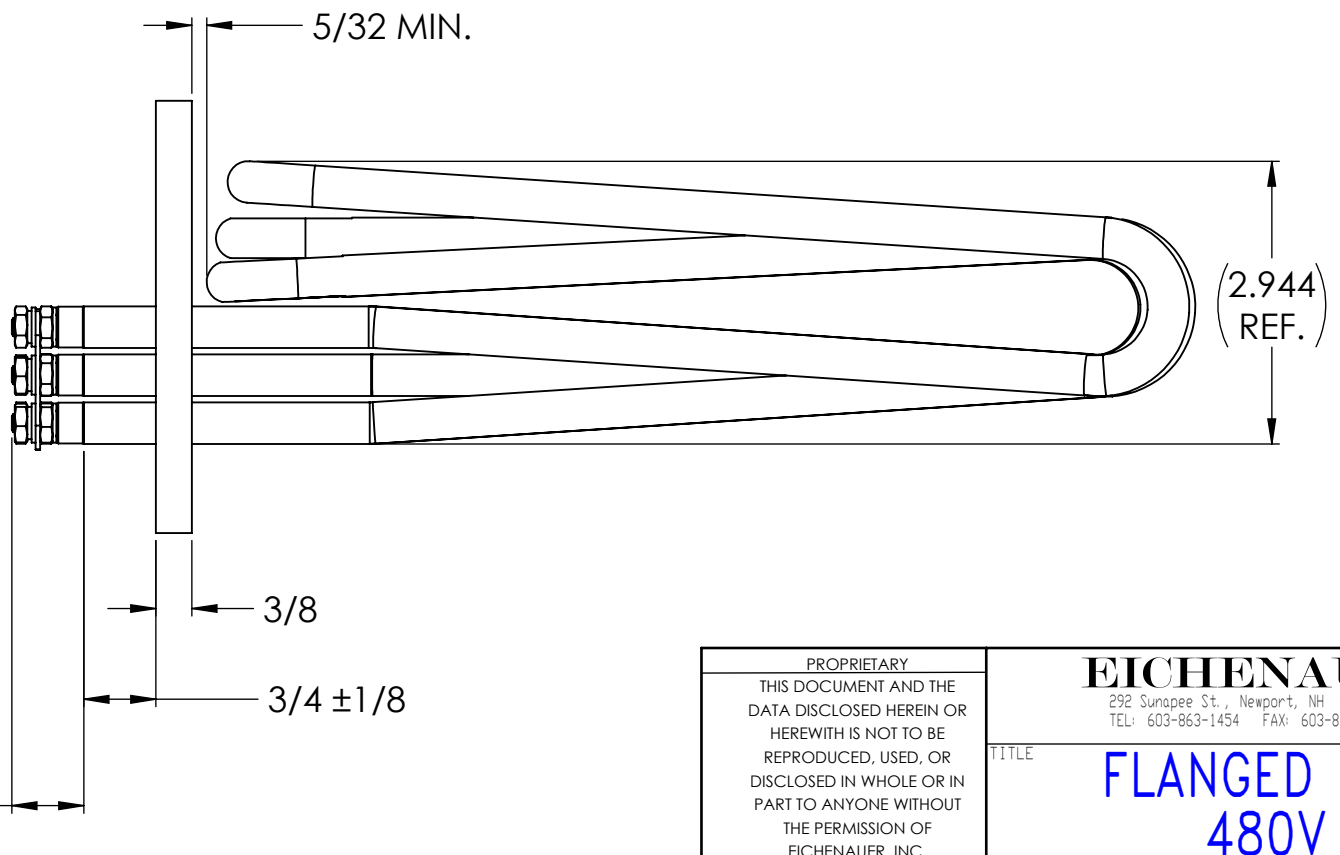
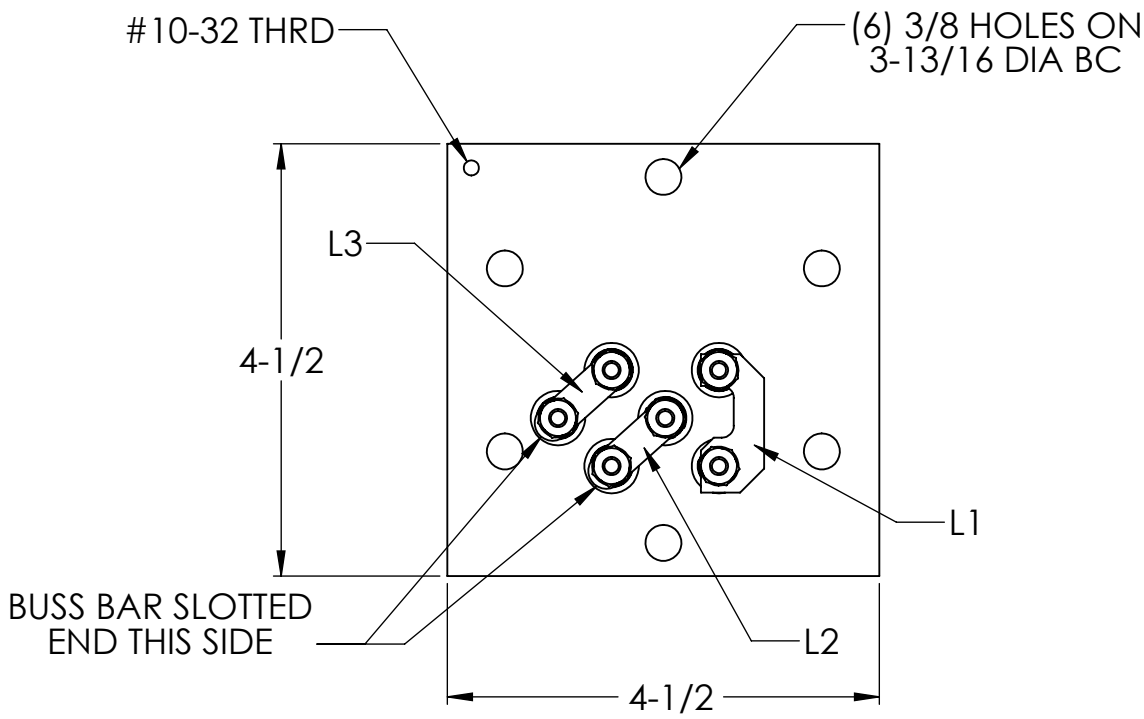
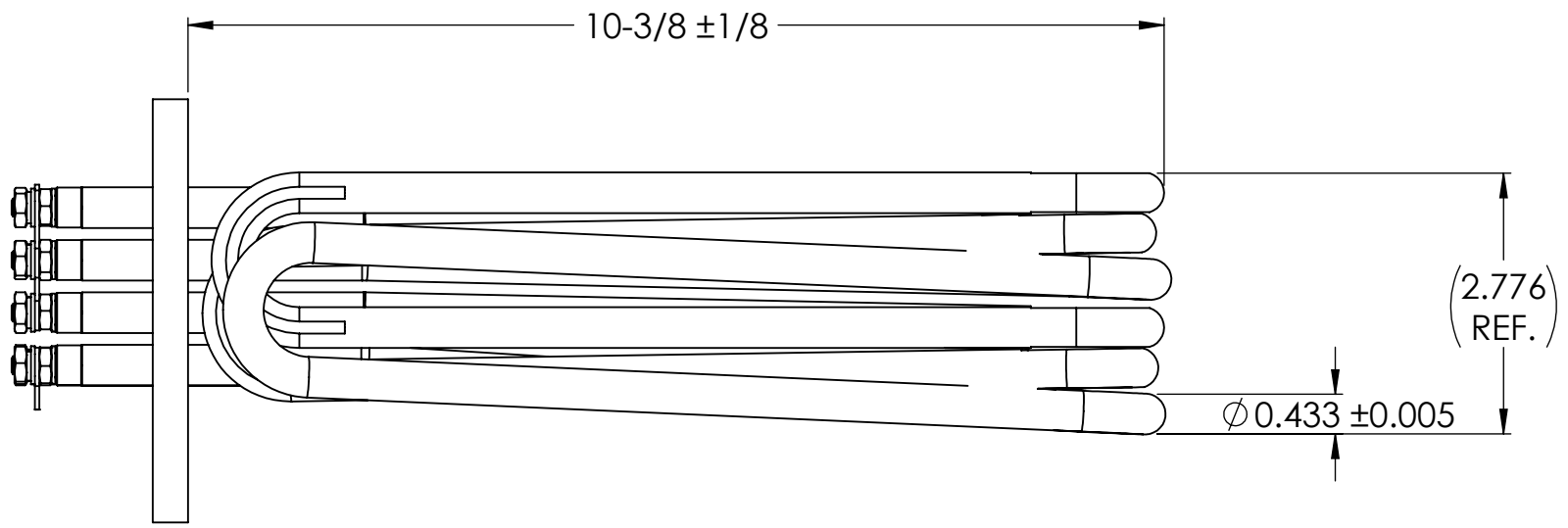

PROPRIETARY THIS DOCUMENT AND THE DATA DISCLOSED HEREIN OR HERewith IS NOT TO BE REPRODUCED, USED, OR DISCLOSED IN WHOLE OR IN PART TO ANYONE WITHOUT THE PERMISSION OF EICHENAUER, INC. THIRD ANGLE PROJECTION	EICHENAUER INC. <small>292 Sunapee St., Newport, NH 03773 TEL: 603-863-1454 FAX: 603-863-1248</small>		
	FLANGED BOILER HEATER 480V 24KW 3PH		
SIZE: B SCALE: N/A	CAGE CODE:	DWG. NO.: 300476H	REV.: 4
		SHEET: 2 OF 2	

4

3

2

1