

THIS DOCUMENT AND THE DATA DISCLOSED HEREIN OR HEREWITH IS NOT TO BE REPRODUCED, USED, OR DISCLOSED IN WHOLE OR IN PART TO ANYONE WITHOUT THE PERMISSION OF HARTFORD EICHENAUER, INC.

REVISIONS			
LTR/NO	DESCRIPTION	DATE	APPROVED
1	PRODUCTION RELEASE	8/21/09	SJH
2	REVISED PER ECN 045-10	11/05/10	SJH
3	LABELS REVISED PER ECN 014-11	6/17/11	SJH

NOTES:

1. DIMENSIONS IN INCHES
2. FLANGE MATERIAL: STEEL
3. SHEATH MATERIAL: 1.4571
4. TERMINAL PINS: #10-32 WITH NUTS & WASHERS AS SHOWN
5. COLD RESISTANCE: 36.1Ω $\pm 10\%/-5\%$ (34.4 - 39.8) PER TUBE
6. TOTAL RESISTANCE: 24.1Ω $\pm 10\%/-5\%$ (22.9 - 26.5) L1-L2, L2-L3, L1-L3
7. TIGHTEN TOP NUTS TO 30 IN-LBS TORQUE
8. SHEATH WATT DENSITY: 119 W/IN²
9. UL FILE: E76225, MODEL 2202
10. WIRING DIAGRAM: WDG-003

24X 52325 FLAT WASHERS
 24X 50471 HEX NUTS
 12X 52470 SPLIT WASHERS

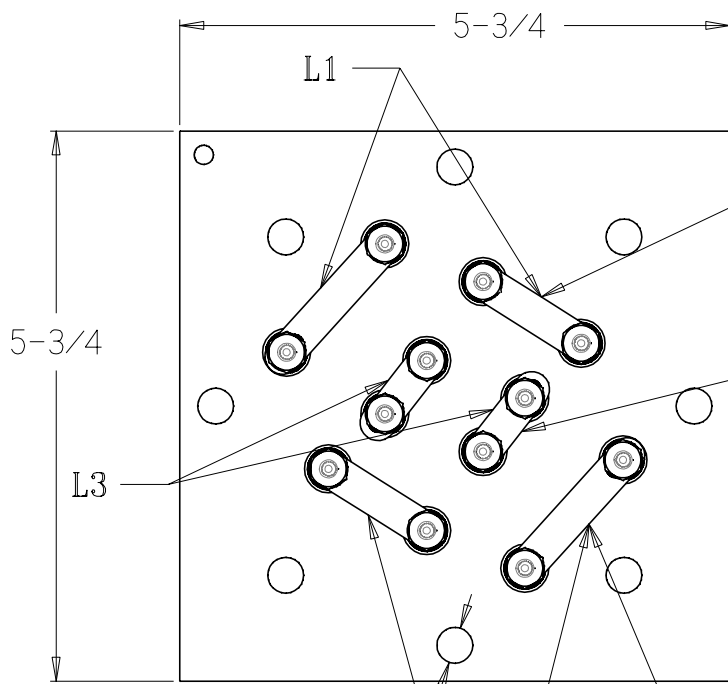
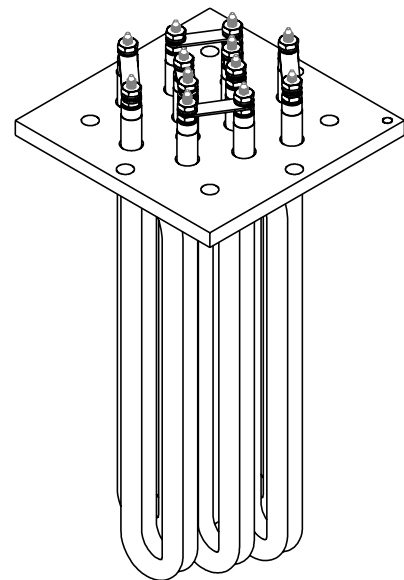

(8) \varnothing 3/8 HOLES ON 5.0 DIA BC

12X 52469

2X 52478

2X 52471

2X 52477

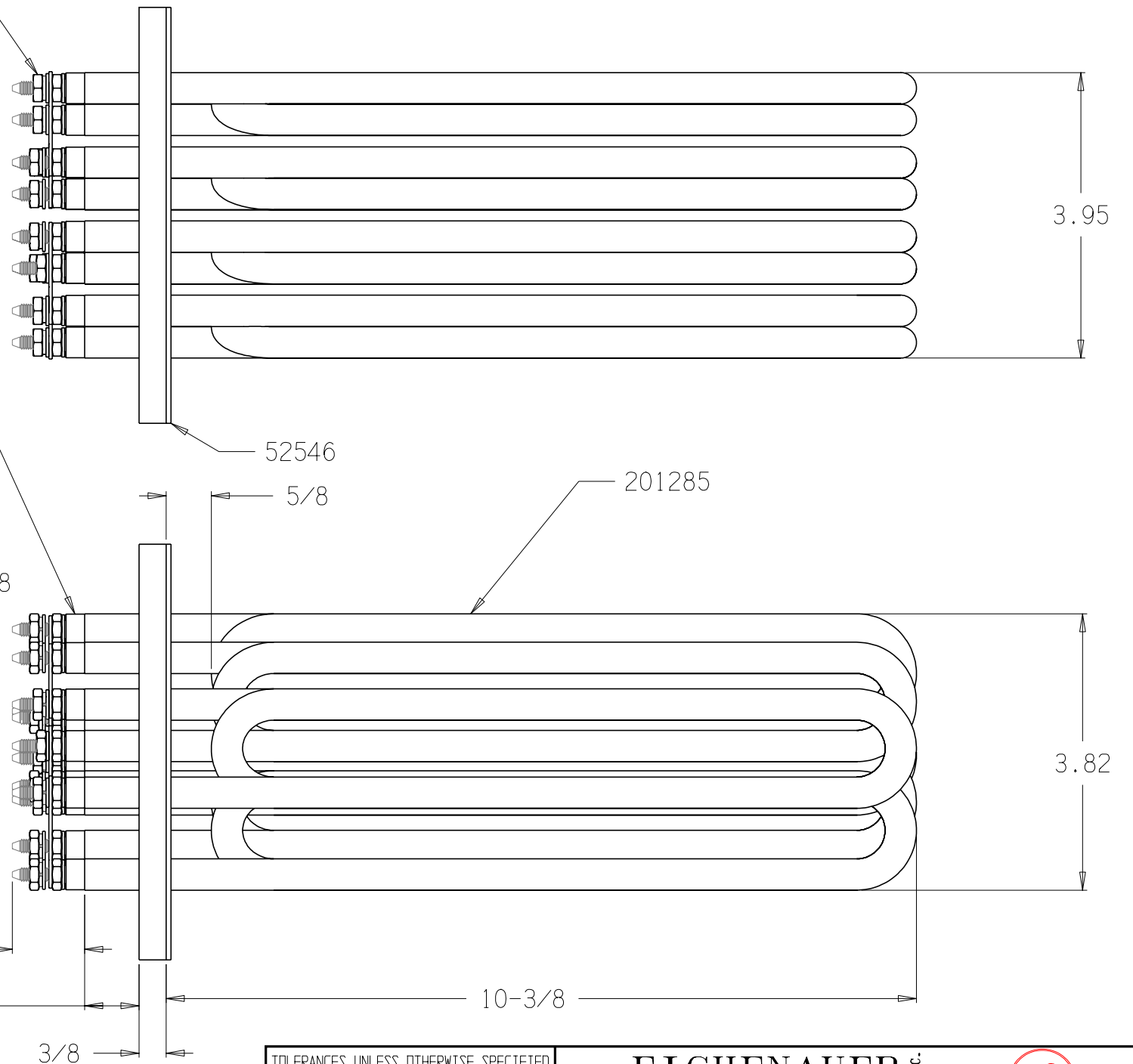

THIRD ANGLE PROJECTION

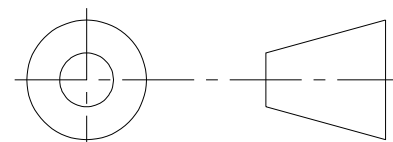

TOLERANCES UNLESS OTHERWISE SPECIFIED		
DEC	FRACTIONS	ANGLES
.X \pm .06		
.XX \pm .025	\pm 1/16	\pm 1°
.XXX \pm .010		

APPROVALS	DATE
DRAWN S. HEBERT	08/21/09
CHECKED	
SCALE 1:2	

EICHENAUER INC.
 292 Sunapee St., Newport, NH 03773
 TEL: 603-863-1454 FAX: 603-863-1248

5-3/4" FLANGED IMMERSERS
480V 37.5KW 3PH

SIZE B FSCM NO. DWG. NO. 300509K REV. 3

SHEET 1 of 1