

4

3

2

1

REVISIONS			
LTR/NO	DESCRIPTION	DATE	APPROVED
3	SEE ECN 042-20	20201026	MDH

NOTES:

1. REMOVED.
2. FLANGE MATERIAL: STAINLESS STEEL
3. SHEATH MATERIAL: 1.4571
4. TERMINAL PINS: M4 X .7 WITH NUTS AND WASHERS AS SHOWN
5. COLD RESISTANCE: 45.2Ω +10%/-5% (43.0 - 49.7) PER TUBE (3 PLACES)
6. COLD RESISTANCE: 30.1Ω +10%/-5% (28.7 - 33.1) L1-L2-L3
7. TIGHTEN TOP NUTS TO: 20 IN-LBS TORQUE
8. MAX SHEATH WATT DENSITY: 68 W/IN<sup>2</sup> (SHORT TUBE)
9. REMOVED.
10. NOT SHOWN: 52367 GASKET

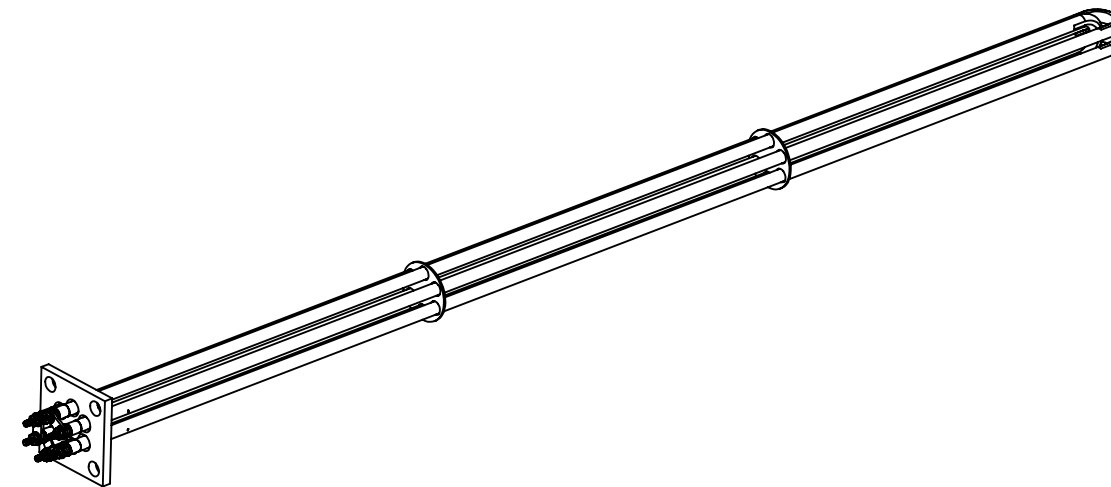
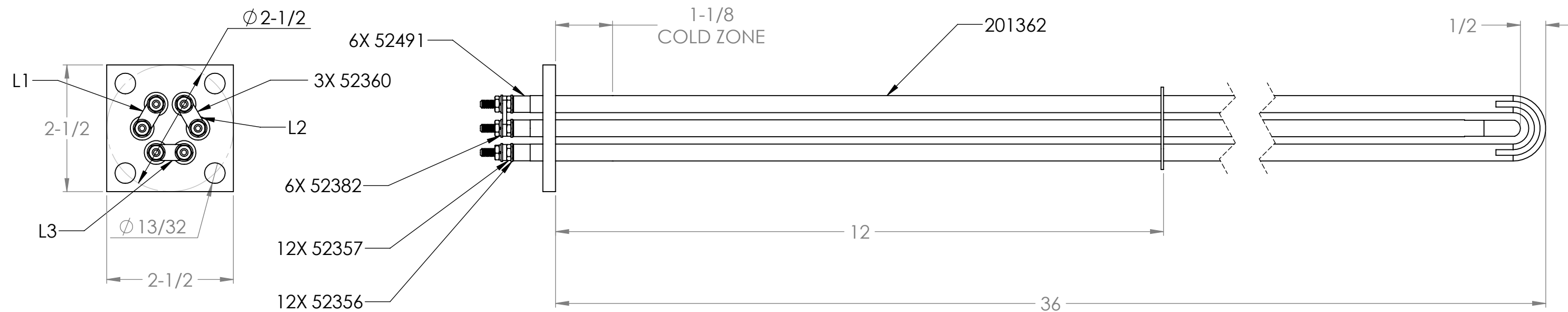
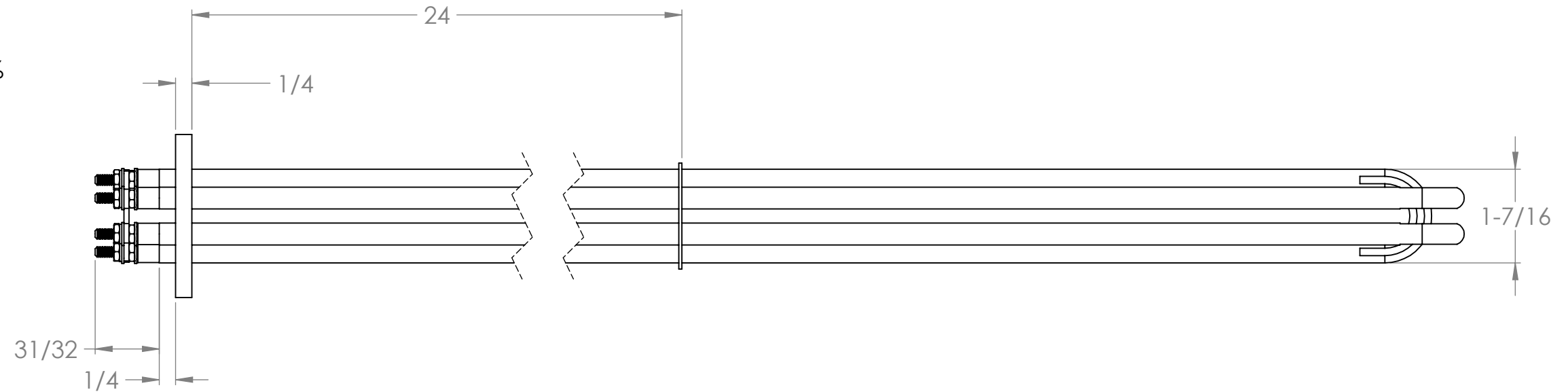

PROPRIETARY THIS DOCUMENT AND THE DATA DISCLOSED HEREIN OR HERewith IS NOT TO BE REPRODUCED, USED, OR DISCLOSED IN WHOLE OR IN PART TO ANYONE WITHOUT THE PERMISSION OF EICHENAUER, INC. THIRD ANGLE PROJECTION	DIMENSIONS UNLESS OTHERWISE SPECIFIED: IN/CM TOLERANCES UNLESS OTHERWISE SPECIFIED: DEC FRACTIONS ANGLES . X ± . 1 . XX ± . 03 ± 1/16 ± 1° . XXX ± . 010	<b>EICHENAUER INC</b> 292 Sunapee St., Newport, NH 03773 TEL: 603-863-1454 FAX: 603-863-1248	
	APPROVALS DRAWN S. HEBERT CHECKED	DATE 12/04/08	TITLE <b>FLANGED BOILER HEATER          480V 15KW 3PH</b>
	SCALE N/A	SIZE <b>B</b>	DWG. NO. <b>300554H</b>
		SHEET <b>1 OF 1</b>	REV. <b>3</b>

4

3

2

1