

4

3

2

1

REVISIONS			
LTR/NO	DESCRIPTION	DATE	APPROVED
2	SEE ECN-042-20	20201027	MDH

NOTES:

1. REMOVED.
2. FLANGE MATERIAL: STEEL
3. SHEATH MATERIAL: 1.4571
4. TERMINAL PINS: 10-32 WITH NUTS AND WASHERS AS SHOWN.
5. COLD RESISTANCE: $27.1\Omega +10\%/-5\%$ (25.8 - 29.8) PER TUBE
6. COLD RESISTANCE: $18.1\Omega +10\%/-5\%$ (17.2 - 19.9) BUSS TO BUSS
7. TIGHTEN TOP NUTS TO 25 IN-LBS TORQUE
8. SHEATH WATT DENSITY: 88 W/IN²
9. UL FILE: E76225 MODEL: 965-30-11

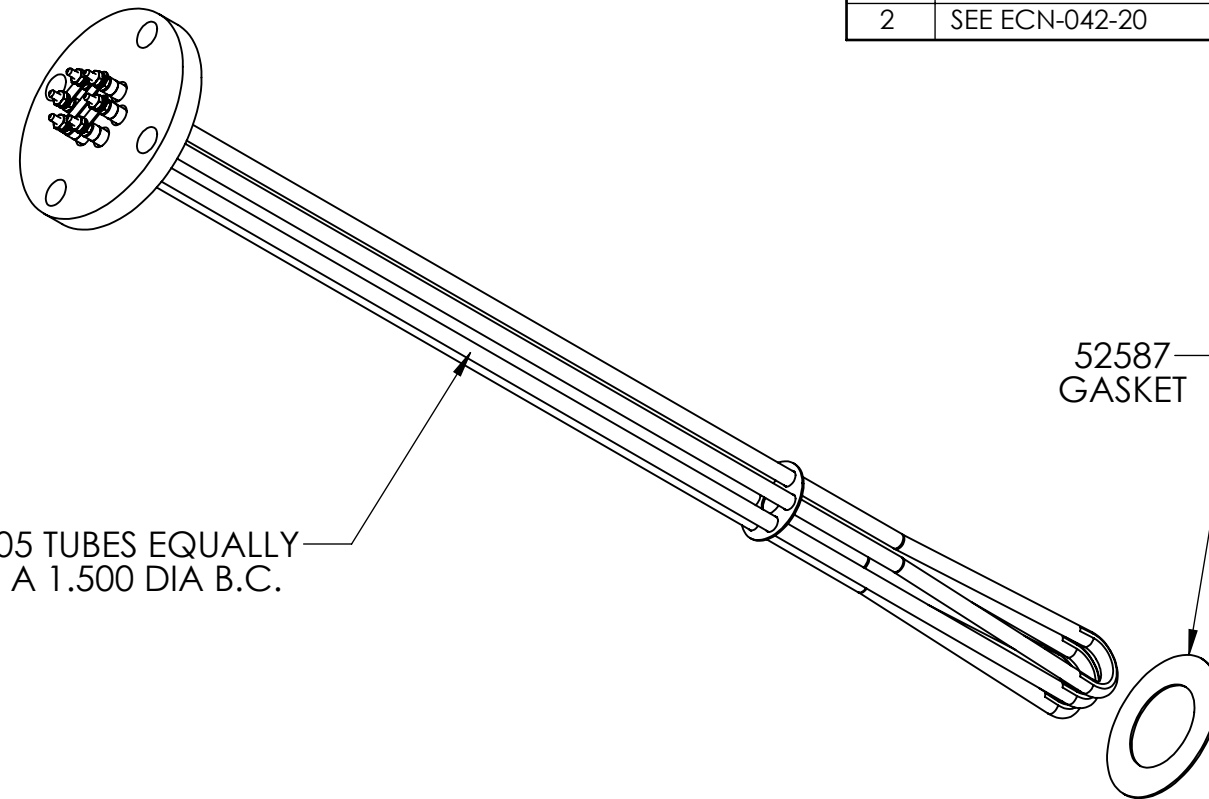

3X Ø.433±.005 TUBES EQUALLY SPACED ON A 1.500 DIA B.C.

52587 GASKET

4X Ø0.75 ON A 4-3/4 DIA B.C.

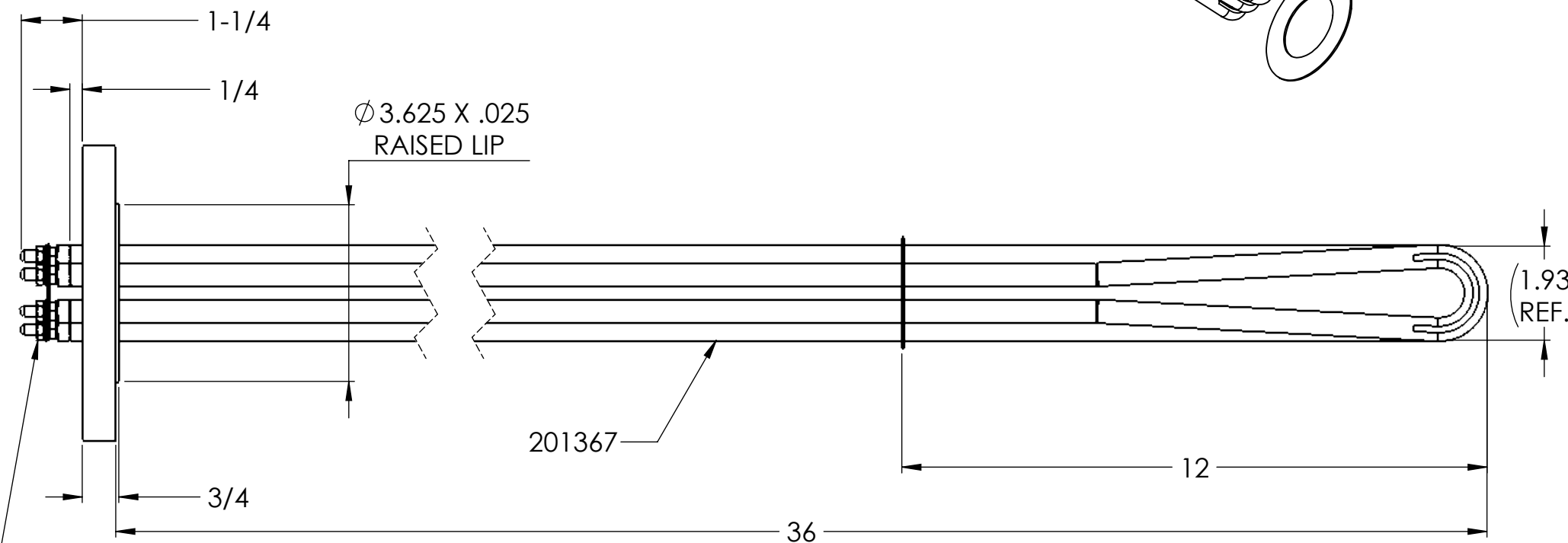
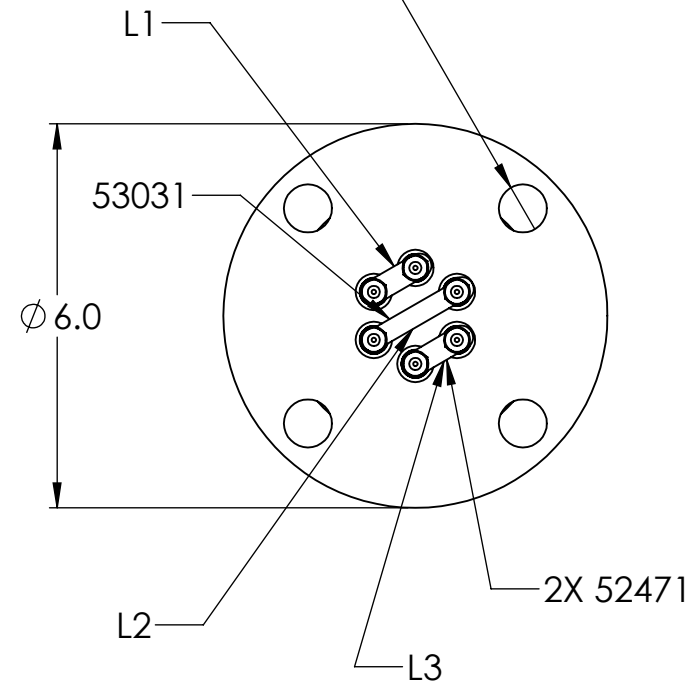

6X 52469
12X 50471
12X 52325
6X 52470

PROPRIETARY THIS DOCUMENT AND THE DATA DISCLOSED HEREIN OR HERewith IS NOT TO BE REPRODUCED, USED, OR DISCLOSED IN WHOLE OR IN PART TO ANYONE WITHOUT THE PERMISSION OF EICHENAUER, INC. THIRD ANGLE PROJECTION	DIMENSIONS UNLESS OTHERWISE SPECIFIED: IN/[MM]		EICHENAUER INC. <small>292 Sunapee St., Newport, NH 03773 TEL: 603-863-1454 FAX: 603-863-1248</small>	
	TOLERANCES UNLESS OTHERWISE SPECIFIED: DEC FRACTIONS ANGLES .X ± .1 .XX ± .03 ± 1/16 ± 1° .XXX ± .010			
	APPROVALS REDRAWN M. HAHN CHECKED NAME		DATE 20201002 YYYYMMDD	
	TITLE FLANGED TUBULAR HEATER 480V 25KW 3PH		SIZE CAGE CODE: B DWG. NO. 300556H REV. 2	
SCALE N/A		SHEET 1 OF 1		

4

3

2

1