

4

3

2

1

REVISIONS			
LTR/NO	DESCRIPTION	DATE	APPROVED
3	SEE ECN-042-20	20201027	MDH

NOTES:

1. REMOVED.
2. FLANGE MATERIAL: STEEL
3. SHEATH MATERIAL: STAINLESS STEEL
4. TERMINAL PINS: 10-32 WITH NUTS AND WASHERS AS SHOWN. TOP NUTS TIGHTENED TO 25 IN-LBS
5. COLD RESISTANCE: $22.6\Omega +10\%/-5\%$ (21.5 - 24.8) PER TUBE
6. COLD RESISTANCE: $15.1\Omega +10\%/-5\%$ (14.3 - 16.6) BUSS TO BUSS
7. SHEATH WATT DENSITY: 105 W/IN²
8. UL FILE: E76225 MODEL: 965-30-11

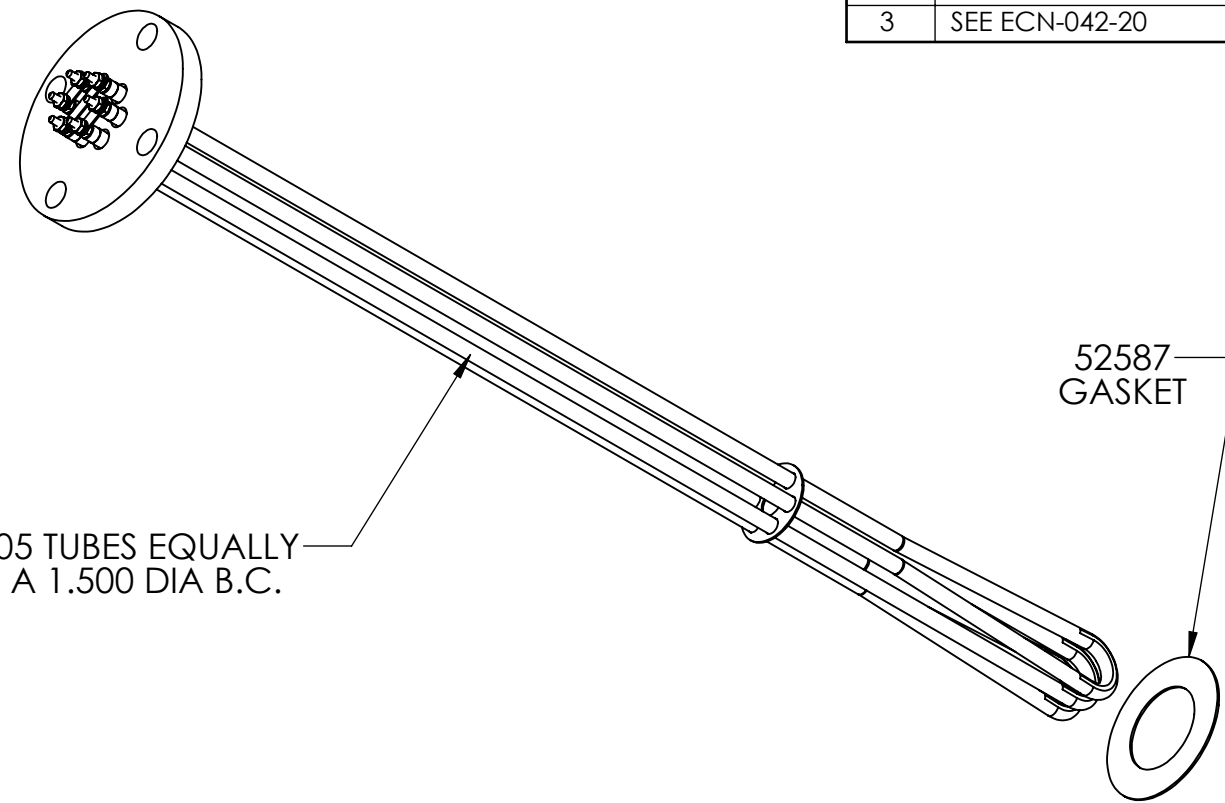

3X Ø.433±.005 TUBES EQUALLY SPACED ON A 1.500 DIA B.C.

52587 GASKET

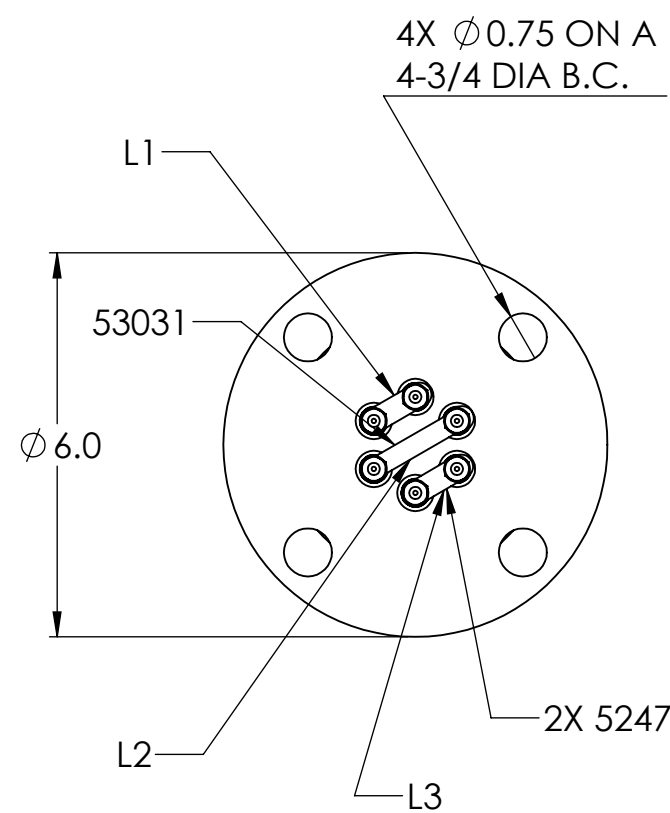

4X Ø0.75 ON A 4-3/4 DIA B.C.

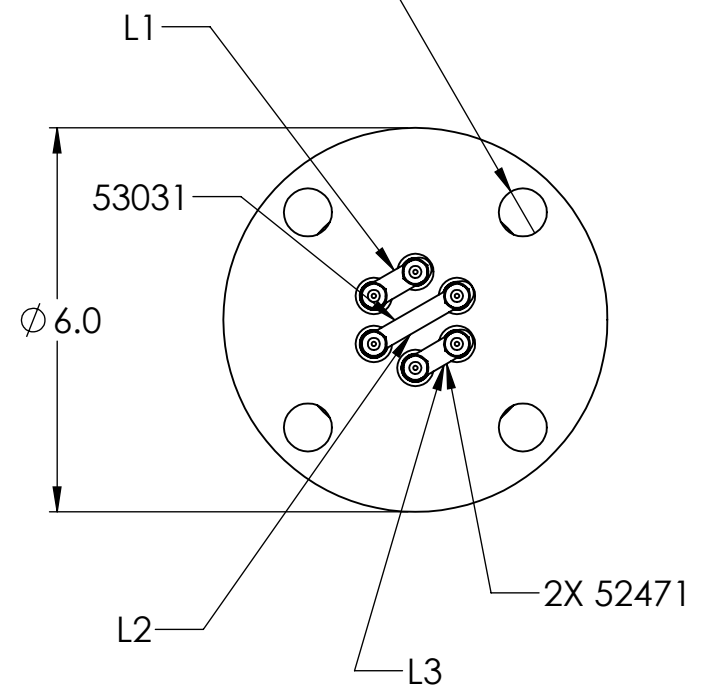

Ø 3.625 X .025 RAISED LIP

6X 52469
 12X 50471
 12X 52325
 6X 52470

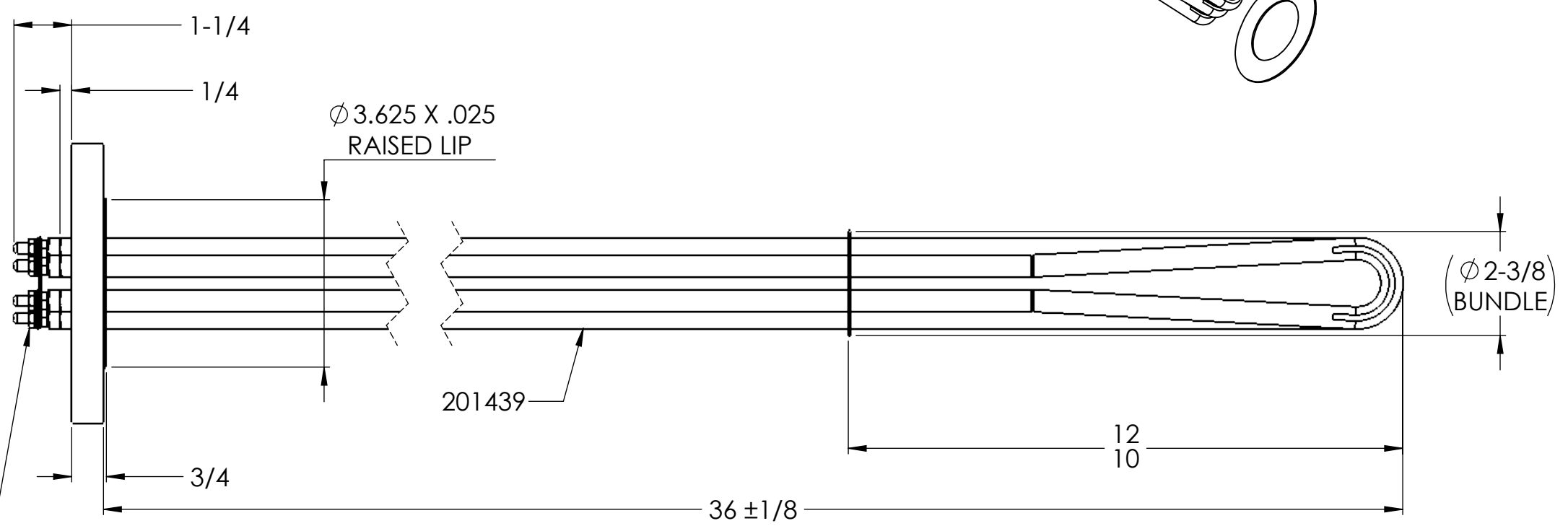

Ø 2-3/8 BUNDLE

PROPRIETARY THIS DOCUMENT AND THE DATA DISCLOSED HEREIN OR HERewith IS NOT TO BE REPRODUCED, USED, OR DISCLOSED IN WHOLE OR IN PART TO ANYONE WITHOUT THE PERMISSION OF EICHENAUER, INC. THIRD ANGLE PROJECTION 	DIMENSIONS UNLESS OTHERWISE SPECIFIED: IN/[MM]		EICHENAUER INC. <small>292 Sunapee St., Newport, NH 03773 TEL: 603-863-1454 FAX: 603-863-1248</small>			
	TOLERANCES UNLESS OTHERWISE SPECIFIED: DEC FRACTIONS ANGLES .X ± .1 .XX ± .03 ± 1/16 ± 1° .XXX ± .010		TITLE FLANGED TUBULAR HEATER 480V 30KW 3PH			
	APPROVALS REDRAWN M. HAHN CHECKED NAME	DATE 20201002 YYYYMMDD	SIZE CAGE CODE: B	DWG. NO. 300585H		REV. 3
	SCALE N/A		SHEET 1 OF 1			

4

3

2

1