

THIS DOCUMENT AND THE DATA DISCLOSED HEREIN OR HEREWITH IS NOT TO BE REPRODUCED, USED, OR DISCLOSED IN WHOLE OR IN PART TO ANYONE WITHOUT THE PERMISSION OF HARTFORD EICHENAUER, INC.

REVISIONS			
LTR/NO	DESCRIPTION	DATE	APPROVED
1	PRODUCTION RELEASE	12/2/10	SJH
2	REMOVED UL NOTE PER ECN 011-18	3/02/18	SJH

NOTES:

1. DIMENSIONS IN INCHES
2. FLANGE MATERIAL: STEEL
3. SHEATH MATERIAL: 1.4571
4. TERMINAL PINS: M4 X .7 WITH NUTS AND WASHERS AS SHOWN
TOP NUTS TIGHTENED TO: 20 IN-LBS
5. COLD RESISTANCE: $8.5\Omega + 10\% / -5\%$
(8.1 - 9.3) PER TUBE
6. COLD RESISTANCE: $5.7\Omega + 10\% / -5\%$
(5.4 - 6.2) ASSMBLED
7. MAX SHEATH WATT DENSITY:
140 W/IN² (SHORT TUBE)
8. WIRING DIAGRAM: WDG-004

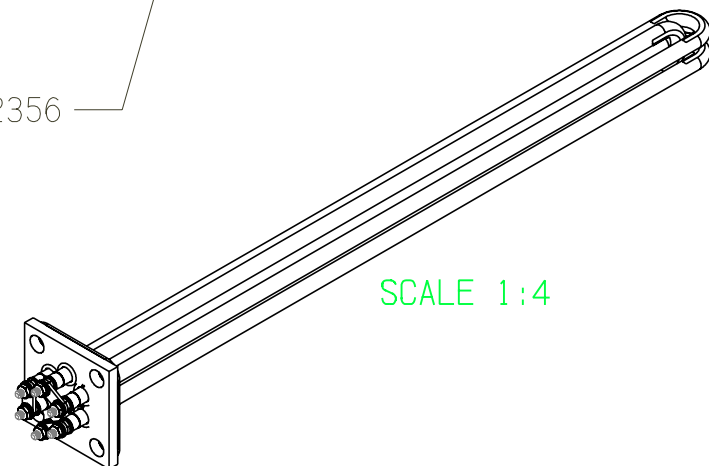
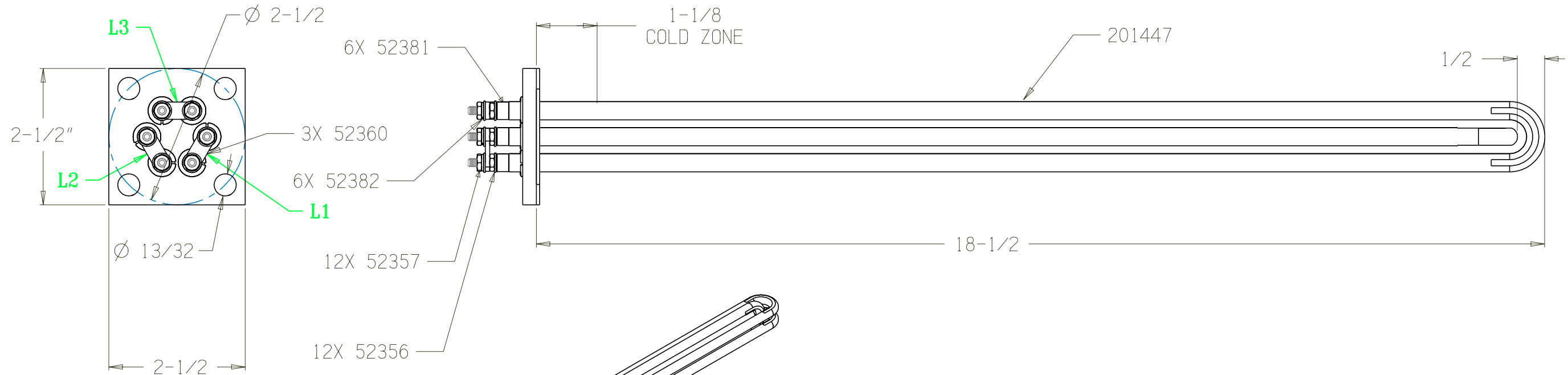
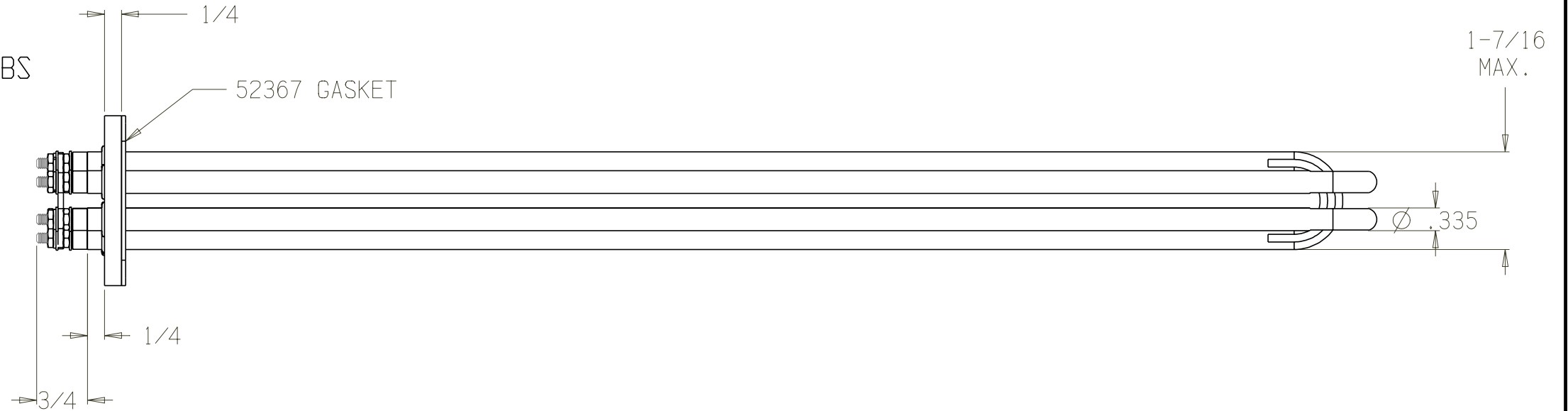

THIRD ANGLE PROJECTION

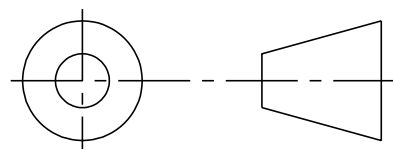

TOLERANCES UNLESS OTHERWISE SPECIFIED	
DEC	FRACTIONS ANGLES
.X ± .06	
.XX ± .025 ± 1/16	± 1°
.XXX ± .010	
APPROVALS	DATE
DRAWN S. HEBERT	12/2/10
CHECKED	

EICHENAUER INC.
292 Sunapee St., Newport, NH 03773
TEL: 603-863-1454 FAX: 603-863-1248

FLANGED BOILER HEATER
208V 15KW 3PH

SIZE FSCM NO. DWG. NO. REV.
B 300590H 2

SCALE 1:2 SHEET 1 of 1